



**BANDEJAS PORTACABLES**

**CABLE TRAYS**

## **INDICE**

### **INDEX**

Página / *Page*

- Datos Técnicos / <i>Technical Specifications</i> .....	3- 9
- Bandeja Perforada (Serie BP) / <i>Perforated tray (BP Series)</i> .....	11- 19
- Bandeja Escalera (Serie BEL) / <i>Ladder tray (BEL Series)</i> .....	20- 28
- Bandeja Escalera (Serie BE) / <i>Ladder tray (BE Series)</i> .....	29- 37
- Canal Cerrado (Serie C) / <i>Closed Channel (C Series)</i> .....	38
- Soportes (Serie SE) / <i>Supports (SE Series)</i> .....	39- 47
- Railes (Serie RL) / <i>Rails (RL Series)</i> .....	48- 49

## INFORME SOBRE EL ENSAYO DE CUALIFICACION SISMICA DE BANDEJAS Y ACCESORIOS IESA CON DESTINO AL MONTAJE EN CENTRALES NUCLEARES.

### *REPORT ON THE SEISMIC RATING TEST OF VARIOUS TYPE OF TRAYS AND ACCESSORIES FOR ASSEMBLY IN NUCLEAR STATIONS*

Una muestra suficientemente amplia de los materiales que componen este catálogo, han sido sometidos a las pruebas de cualificación sísmica que establece el IEE en su norma 34-1975 para determinar con toda precisión el comportamiento mecánico de nuestras bandejas y soportes para las mismas, en las condiciones más difíciles.

*A large sample of the materials includes in this catalogue, have been subjected to various seismic tests in accordance with IEE Standard number 34-1975 to determinate precisely the mechanical behaviour of our trays and supports in the most difficult conditions.*

Las bandejas fueron colocadas sobre una plataforma de ensayos (Foto 1) de acción biaxial simultánea, impulsada por un actuador de frecuencia y aceleración variables, en el cual el movimiento vertical es igual al horizontal actuando ambos simultáneamente.

*Trays were placed on the test platform (Photography nº 1) with simultaneous biaxial action and impulsed by one function of frequency and variable acceleration for both directions (vertical and horizontal).*

Se determinan las curvas del factor de amplificación y las frecuencias de resonancia (11Hz en dirección vertical en ambas posiciones, 25 Hz para la posición XZ y 11,2 Hz para la posición YZ).

*The curves have provided the values of the amplification factor and the resonance frequencies (11Hz in a vertical direction in both positions, 25 Hz for position XZ and 11,2 Hz for position YZ).*

Estos datos corresponden a las bandejas serie BEL; la bandeja perforada presenta una frecuencia de resonancia de 7 Hz para la dirección vertical y de 47 Hz en dirección horizontal.

*These data correspond to BEL series trays. Perforated tray exhibits a resonance frequency of 7 Hz in a vertical direction and 47 Hz in horizontal direction.*

Posteriormente se realizan los ensayos con onda senoidal continua a las frecuencias de resonancia de las bandejas, para determinar los amortiguamientos que oscilan entre 3,1 y 7,5 en la dirección horizontal y 2,3 y 4,7 para la dirección vertical.

*Subsequently, the sequence of test is carried out with the trays with a continuous sinusoidal wave at the resonance frequencies, for determining the damping values. The values range between 3,1 and 7, for the horizontal direction, and between 2,3 and 4,7 for the vertical direction.*

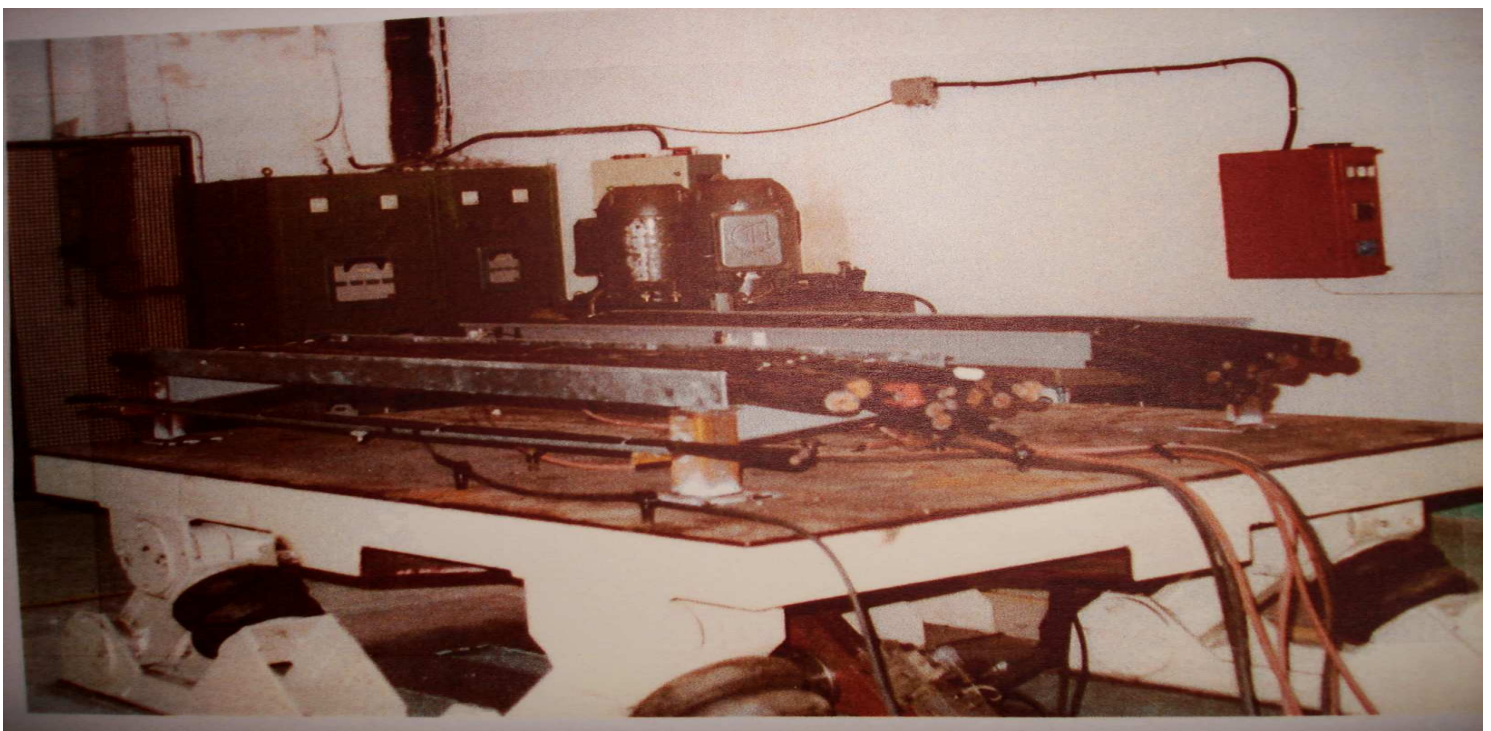

De otros ensayos con multifrecuencia de banda ancha, realizados en las dos direcciones principales de la plataforma se obtuvieron los TRS para los amortiguamientos del 2,5, 5 y 10 % (Fig. B) que cubren la curva obtenida de la norma 344-1975 (Fig. A).

*From other test seismic rating test performed with a broad band multifrequency for both directions of the test platform, we have obtained the TRS for the accelerometer, drawn for 2,5 and 5 and 10 % (Fig. B) damping, according to 344-1975 Standard (Fig. A).*

Todas estas pruebas han sido realizadas lastrando las bandejas con cables hasta un peso de 150 Kgs. por bandeja.

*All these test have been carried out loading trays with cables up to 150 Kgs.per tray.*

Simultáneamente se han medido los esfuerzos mecánicos de la estructura, a flexión, torsión y cizalladura, comportamiento de las uniones de travesaños a la largueros, etc.

*Simultaneously we have measured the mechanical efforts of the structure, flexión, twisting and clipping behaviour of unions of transoms to jambs, etc.*

Los resultados en todos los ensayos, que constan en la documentación que de ellos poseemos, es que todos los materiales han soportado las pruebas sin que se detecte ninguna deformación estructural ni rotura, ni cualquier otra anomalía.

*The results of the essays indicate that all the material have supported all the test, detecting neither structural deformations nor breaks or any anomaly.*

La conclusión es que nuestros fabricados han superado las pruebas que establece el IEE para la cualificación sísmica y que son aptos para su montaje en instalaciones que requieren esta condición.

*The conclusion is that our products have surpassed all the proofs established by IEE for the seismic qualification and they are suitable for assembly on installations in this conditions.*

Aportando estos datos creemos haber contribuido a un conocimiento más en profundidad de nuestra fabricación por parte de nuestros clientes.

*We hope our clients understanding in great detail our manufacture, with the documentation remitted.*

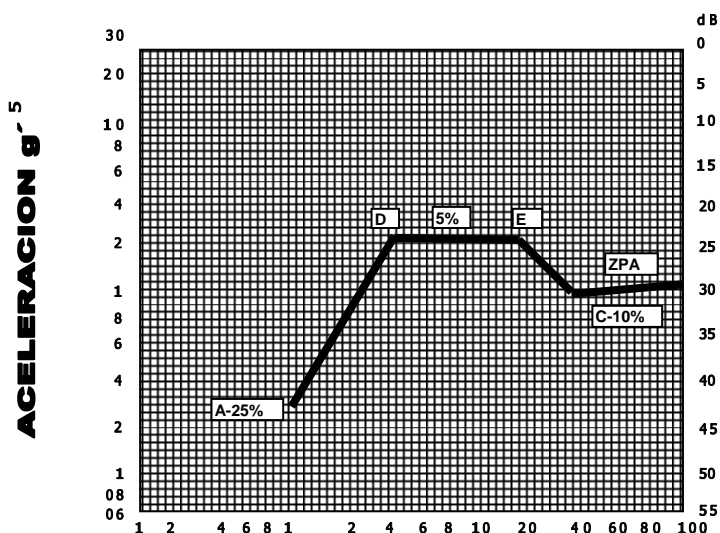

Fig. A

**FRECUENCIA Hz**

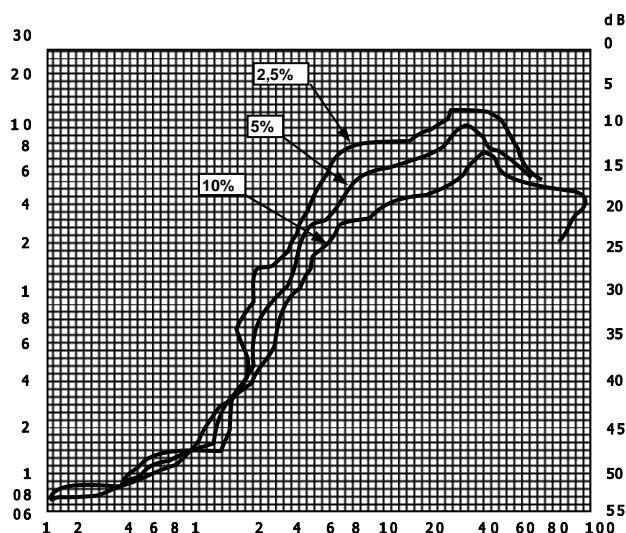

Fig. B

## **MATERIALES / MATERIALS**

Las bandejas IESA están construidas con acero laminado en frío de primera calidad. Bajo demanda se pueden fabricar en otros materiales, como aluminio, fibras especiales, PVC, etc.

*The raw material for the manufacture of tray is top quality sheet cold steel. Upon request, other materials (aluminium, special fibres, PVC, etc.) are available.*

Las bandejas perforadas y cerradas se construyen en acero laminado en frío, que posteriormente se protege con alguno de los sistemas abajo descritos, o de chapa laminada en frío y galvanizada en banda por el procedimiento SENDZIMIR.

*The perforated trays and sheet cold steel made and coated with one of the systems set up below, or sheet plate galvanized by SENDZIMIR procedure.*

La tornillería es de acero, y en casos especiales en acero inoxidable.

*The screws are steel made, and in special cases stainless steel.*

## **REVESTIMIENTOS / COATING**

Los revestimientos que para este tipo de material tenemos estandarizados son los siguientes:

*The coating for this type of material are as follows:*

### **GALVANIZADO POR INMERSION EN CALIENTE / HOT DIP GALVANIZED**

Este procedimiento de recubrir el acero consiste en la introducción de las piezas en una cuba llena de zinc fundido.

*This metallurgical process to coat steel or iron with zinc consists of dipping the pieces in one barrel full of hot melted zinc.*

Previamente es necesario decapar con ácidos para eliminar los óxidos superficiales.

*Previously, it is necessary to scrape with acids to dispose of the superficial oxides.*

La superficie de las bandejas queda totalmente cubierta por una capa de zinc de un espesor que oscila entre 70 y 120 micras. Las características de este revestimiento frente a la corrosión son sobradamente conocidas: no se produce oxidación en tanto quede sobre la superficie de la pieza recubrimiento de zinc.

*The surface of the trays will be zinc-plate with a thickness between 70 and 120 microns. The characteristics of this type of coating on corrosion are well known: there is not oxidation until zinc does not disappear.*

### **RECUBRIMIENTO DE RESINA EPOXY-POLIESTER / COATING OF EPOXY POLYESTER RESIN**

Consiste en proyectar electrostáticamente sobre la superficie de las piezas previamente preparadas, tras un proceso especial, unas resinas de epoxy en partículas de diverso micraje.

*It consists of projecting electrostatically some resins of epoxy on the surface of the piece that piece that is prepared previously.*

La protección es de una gran resistencia mecánica, y muy eficaz contra la corrosión incluso en ambientes húmedos o salinos. La superficie resultante es muy adecuada para el contacto con los cables por no presentar elementos que puedan dañarlo y proporciona además un buen aislamiento eléctrico.

*The protection has a great mechanical resistance, and it is effective against the corrosion, even in damp or saline environment. The resulting surface is suitable for the contact with the cables because it does not have elements that can spoil it and provides a good electrical insulation as well.*

Los espesores que se obtienen varían de 40 a 140 micras. Los colores más usuales son el gris y el rojo óxido.

*The thickness goes to up 40 microns. The common colours are grey and red oxide.*

#### **RECUBRIMIENTO CON LEVASINT / COATING WITH LEVASINT**

Se sumergen las piezas en un baño fluidificado de polvo de LEVASINT, previo tratamiento superficial con chorro de arena. Proporciona un revestimiento eficaz a la corrosión en ambientes muy húmedos, salinos y químicos. Es aislante y deja una superficie muy adecuada para el tendido de cables. Los espesores varían de 0,2 a 0,4 mm.

*The pieces are dyed in fluidized plating dust, after a superficial treatment with a sand jet. It provides an effective coating against corrosion in damp, chemical and saline environments. It is insulating and allows a suitable surface for electrical installation. Thickness is between 0,2 to 0,4 mm.*

#### **RECUBRIMIENTO CON LEVASINT Y ELECTROCINCADO / COATING WITH LEVASINT ELECTROLYTIC ZINC**

Idem que el tratamiento anterior, pero con previo electrocincado por deposición en cuba electrolítica de 15 a 20 micras de espesor, aumenta la protección de las bandejas. No es posible su aplicación en la serie BE; por imperativo del tamaño de las piezas.

*Idem the previous treatment, but it is realized after one electrolytic zinc by deposition in an electrolytic barrel of 15 to 20 microns of thickness that increases the protection of the trays. It is not possible in BE series because of the length of the pieces.*

#### **RECUBRIMIENTO ELECTROCINCADO / COATING ELECTROLYTIC ZINC**

Consiste en la introducción de las piezas en una cuba electrolítica, donde el zinc se deposita en un espesor de 15 a 20 micras.

*It consists of the introduction of the pieces in an electrolytic barrel, where the zinc is deposited with a thickness between 15 to 20 microns.*

## ENSAYO MECANICO / MECHANICAL TEST

Apoyadas las bandejas BEL (perfil 1) sobre dos soportes situados a 1940 mm entre sí y fijada la bandeja a los mismos con nuestra grapa de fijación, se fue lastrando la bandeja hasta 500 Kg. por considerar que es un máximo suficientemente indicativo. Las mediciones se efectuaron con un juego de galgas Jhonsom.

*BEL Trays (profile 1) are fastened with two supports brackets situated 1940 mm between themselves and fixed to them with our fixing clamp. Then trays were loaded up to 500 Kg. measurement were made with a set of Jhonsom gauges.*

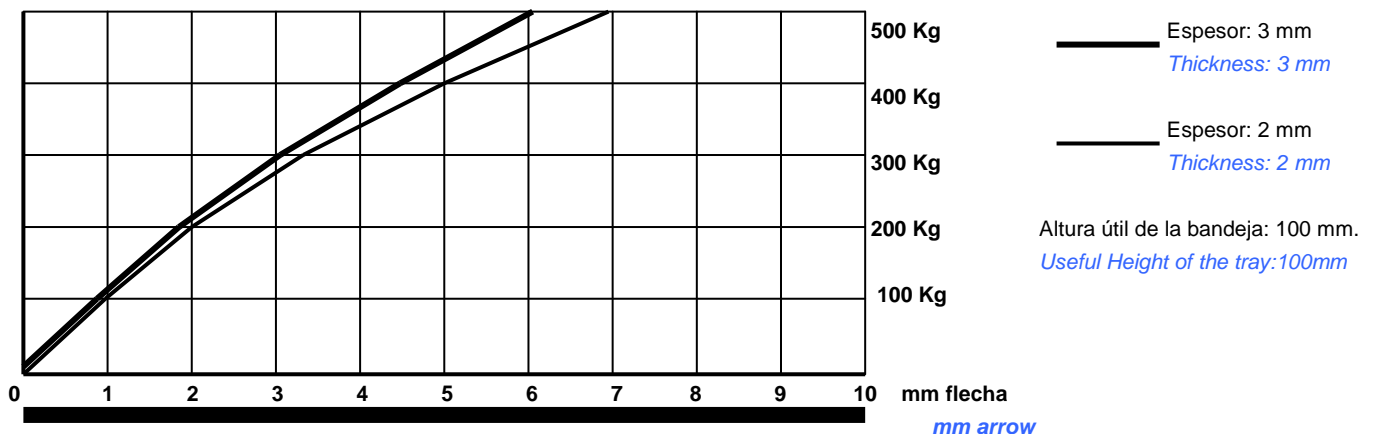
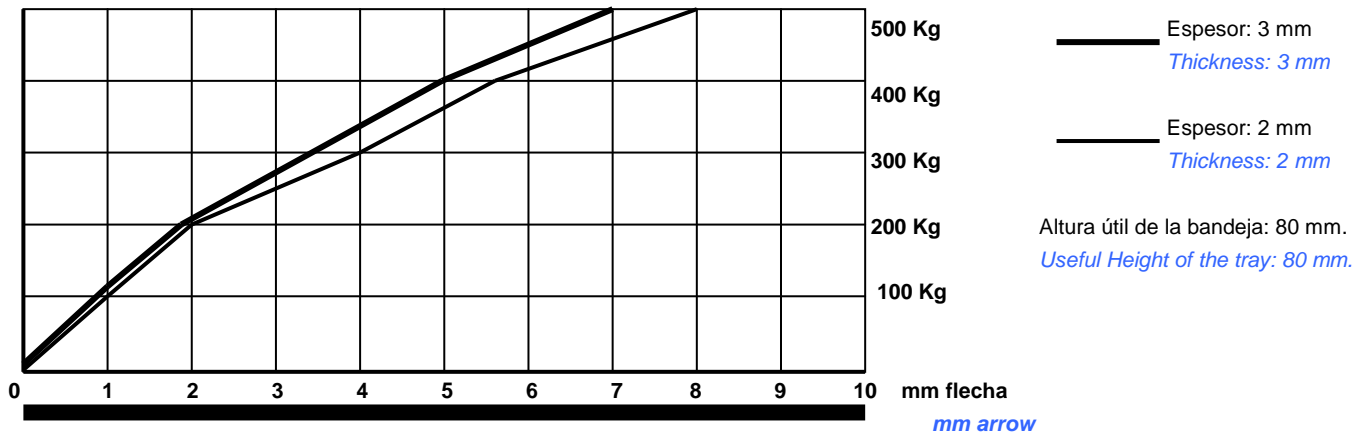
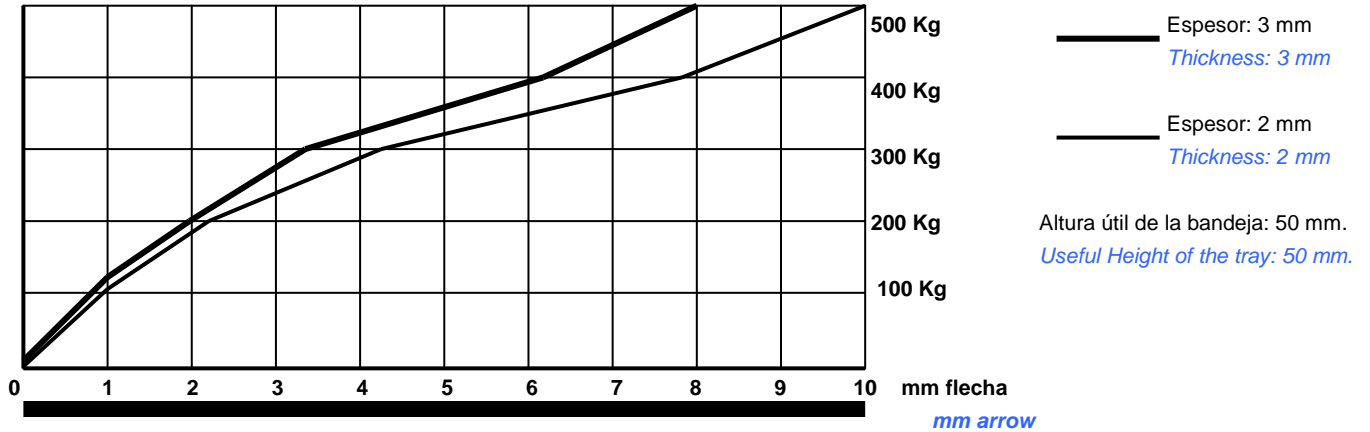

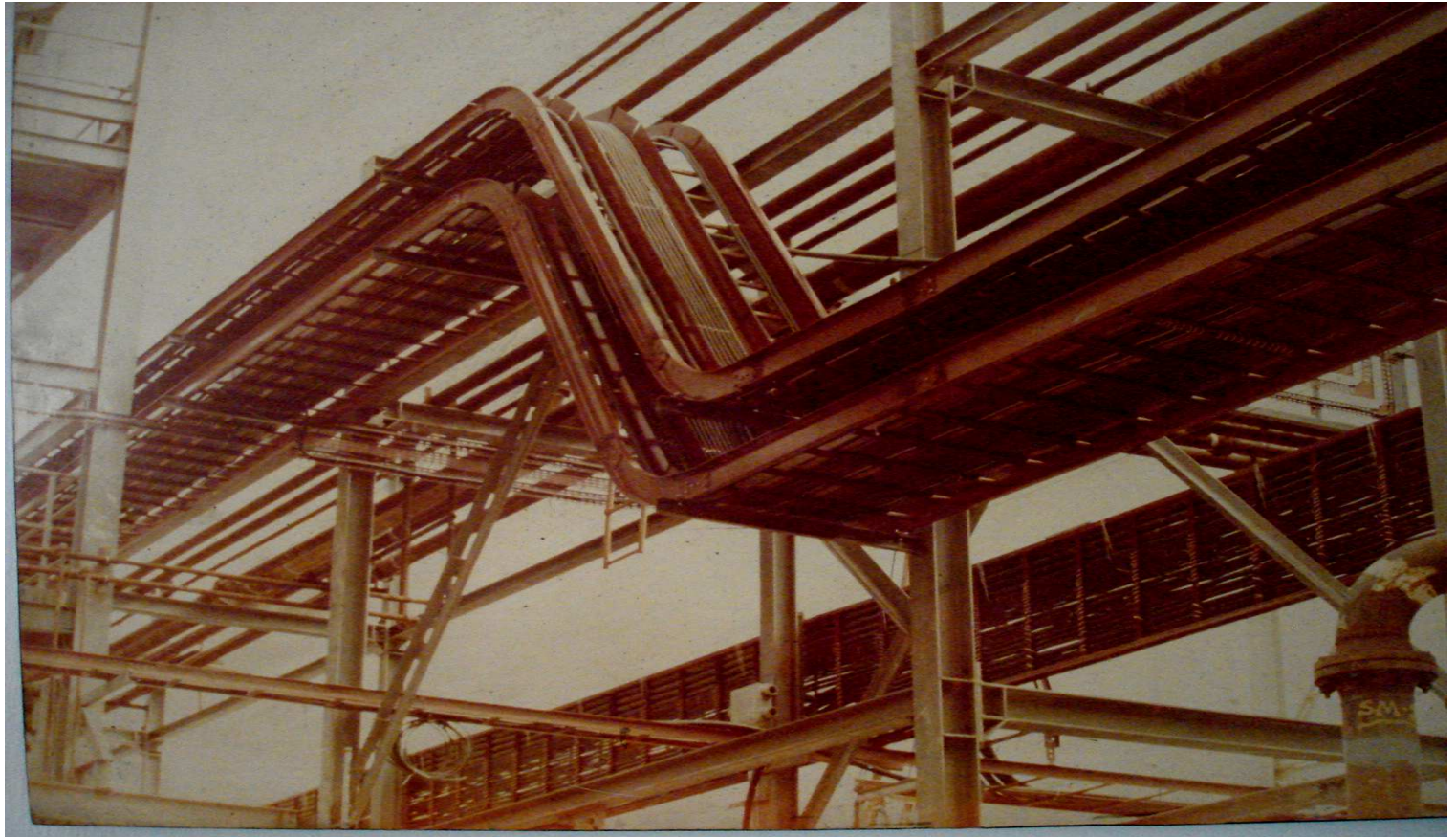

**NOTA:** Para las bandejas de serie BE, representadas en esta foto (Planta de Alúmina Española, San Ciprián, Lugo), la disposición del tendido eléctrico, así como la capacidad de la canalización no es posible estandarizarla, por ser material destinado a instalaciones especiales; razón por la cual no hemos publicado el gráfico de capacidad de cables.

*NOTE: The electrical installation of BE series trays ( Photograph above: "Aluminia Española Plant, San Ciprian - Lugo - Spain ) and its capacity of channelling, cannot be standardized, because it is a material for special installations. For this reason, we have not published the graphic of cables capacity.*

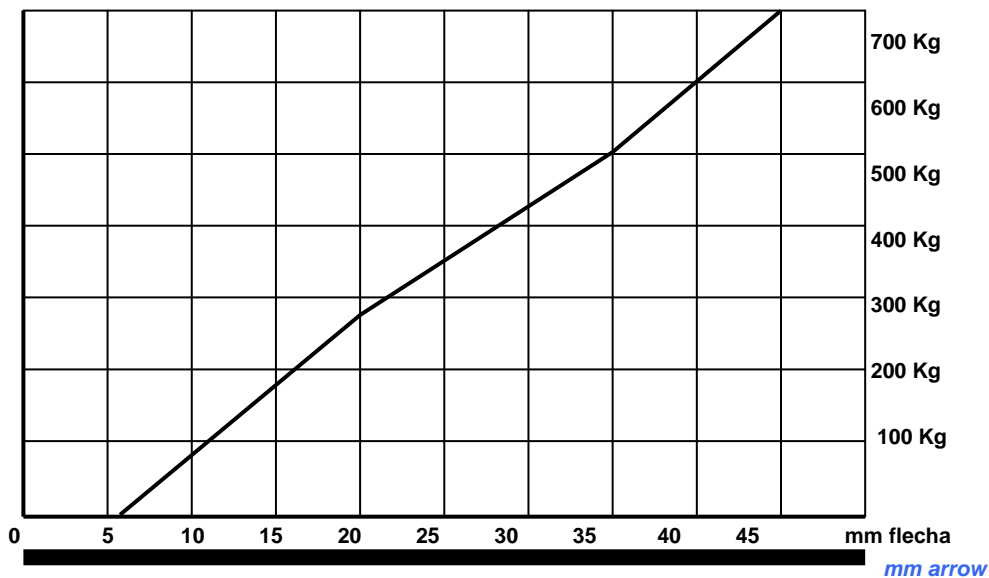

Altura útil de la bandeja: 80 mm.  
Useful Height of the tray: 100mm

Ancho de la bandeja: 600 mm.  
Width of the tray: 600 mm.

Este gráfico corresponde al comportamiento de una bandeja de escalera serie BE, apoyada en dos soportes distantes entre sí 5.900 mm.

*This graphic corresponds to the behaviour of one BE series tray supported in two supports brackets situated 5.900 mm between them selves.*



**CAPACIDAD DE CABLES DE LAS BANDEJAS Serie BEL / CAPACITY OF THE SERIES BEL TRAYS**

Es recomendable no agotar las posibilidades de la capacidad de la bandeja para facilitar los trabajos en el montaje del tendido eléctrico.

*It is recommended not to exhaust the possibilities of the capacity of the tray to facilitate the works in the electrical installations.*

Sección cable Section cable	Ø mm	Peso Weight Kg/m	ANCHURA DE CANAL: 100 mm Width of channel: 100 mm						ANCHURA DE CANAL: 200 mm. Width of channel: 200 mm.					
			Alt. Libre 50 Heig. Free 50		Alt. Libre 80 Heig. Free 80		Alt. Libre 100 Heig. Free 100		Alt. Libre 50 Heig. Free 50		Alt. Libre 80 Heig. Free 80		Alt. Libre 100 Heig. Free 100	
			Nº cables	Kg/m	Nº cables	Kg/m	Nº cables	Kg/m	Nº cables	Kg/m	Nº cables	Kg/m	Nº cables	Kg/m
1,5	13	0,22	24	5,2	56	12,3	70	15,4	43	9,4	105	23,1	131	28,8
2,5	14	0,30	21	6,3	49	14,7	61	18,3	40	12,0	96	28,8	120	36,0
4	16	0,40	18	7,2	36	14,4	45	18,0	34	13,6	72	28,8	90	36,0
6	17	0,51	15	7,6	25	12,7	31	15,8	32	16,3	55	28,0	68	34,6
10	19	0,71	10	7,1	25	17,7	31	22,0	20	14,2	50	35,5	62	44,0
16	22	1,05	8	8,4	15	15,7	18	18,9	16	16,8	43	45,1	53	55,6
25	27	1,60	6	9,6	8	14,4	10	16,0	13	20,8	23	41,6	28	44,8
35	29	2,10	6	12,6	9	18,9	11	23,1	12	25,2	18	37,8	22	46,2
50	34	2,94	4	11,7	6	17,6	7	20,5	7	20,5	15	44,1	18	52,9
70	38	3,87	2	11,6	5	19,3	6	23,2	7	27,0	14	54,1	17	65,7
95	44	5,18	2	10,3	4	20,7	5	25,9	4	20,7	8	41,4	10	51,8
120	47	6,73	2	12,6	3	18,9	3	18,9	3	18,9	8	50,6	10	67,3
150	52	7,79	1	7,8	2	15,5	2	15,5	3	23,3	9	70,1	11	85,6
185	59	9,69	1	9,7	2	19,4	2	19,4	3	29,0	6	58,1	7	67,8
240	71	13,00	1	13,0	1	13,0	1	13,0	2	26,0	2	26,0	2	26,0
Sección cable Section cable	Ø mm	Peso Weight Kg/m	ANCHURA DE CANAL: 300 mm Width of channel: 300 mm						ANCHURA DE CANAL: 400 mm. Width of channel: 400 mm.					
			Alt. Libre 50 Heig. Free 50		Alt. Libre 80 Heig. Free 80		Alt. Libre 100 Heig. Free 100		Alt. Libre 50 Heig. Free 50		Alt. Libre 80 Heig. Free 80		Alt. Libre 100 Heig. Free 100	
			Nº cables	Kg/m	Nº cables	Kg/m	Nº cables	Kg/m	Nº cables	Kg/m	Nº cables	Kg/m	Nº cables	Kg/m
1,5	13	0,22	67	14,7	182	40,0	227	49,9	89	19,5	239	52,5	298	65,5
2,5	14	0,30	61	18,3	145	43,5	181	54,3	83	24,9	195	58,5	243	72,9
4	16	0,40	52	20,8	107	42,8	133	53,2	72	28,8	144	57,6	180	72,0
6	17	0,51	50	25,5	100	51,0	125	63,7	68	34,8	137	69,8	171	87,2
10	19	0,71	29	20,5	74	52,5	92	65,3	40	28,4	100	71,0	125	88,7
16	22	1,05	25	26,2	50	52,5	62	65,1	35	36,7	89	93,4	111	16,5
25	27	1,60	20	32,0	42	67,2	52	83,2	27	43,2	56	89,6	70	12,0
35	29	2,10	18	37,8	38	79,8	47	98,7	25	52,5	52	109,2	65	136,5
50	34	2,94	8	23,5	24	70,5	30	88,2	11	32,3	33	97,0	41	120,5
70	38	3,87	7	27,0	19	73,5	23	89,0	9	34,8	29	112,2	36	139,3
95	44	5,18	4	20,7	17	88,0	21	108,7	9	46,6	17	88,0	21	108,7
120	47	6,73	4	25,3	12	75,9	15	100,9	8	50,6	16	101,2	20	134,6
150	52	7,79	4	31,1	9	70,1	11	85,6	6	46,7	14	116,8	17	132,4
185	59	9,69	4	38,7	9	87,2	11	106,5	5	48,4	12	116,2	15	145,3
240	71	13,00	3	39,0	7	91,0	8	104,0	3	39,0	10	130,0	12	156,0
Sección cable Section cable	Ø mm	Peso Weight Kg/m	ANCHURA DE CANAL: 500 mm Width of channel: 500 mm						ANCHURA DE CANAL: 600 mm. Width of channel: 600 mm.					
			Alt. Libre 50 Heig. Free 50		Alt. Libre 80 Heig. Free 80		Alt. Libre 100 Heig. Free 100		Alt. Libre 50 Heig. Free 50		Alt. Libre 80 Heig. Free 80		Alt. Libre 100 Heig. Free 100	
			Nº cables	Kg/m	Nº cables	Kg/m	Nº cables	Kg/m	Nº cables	Kg/m	Nº cables	Kg/m	Nº cables	Kg/m
1,5	13	0,22	112	24,6	302	66,4	377	82,9	135	29,7	313	68,8	391	86,0
2,5	14	0,30	103	30,9	243	72,9	303	90,9	125	37,5	293	87,9	366	109,8
4	16	0,40	90	36,0	180	72,0	225	90,0	110	44,0	221	88,4	276	110,4
6	17	0,51	86	43,0	173	88,2	216	110,0	104	53,0	209	106,5	261	133,1
10	19	0,71	52	36,9	129	91,5	161	114,3	62	44,0	155	110,0	193	137,0
16	22	1,05	43	45,1	110	115,5	137	143,8	54	56,7	135	147,7	168	176,0
25	27	1,60	35	56,0	71	113,6	88	140,8	43	68,8	88	140,8	110	176,0
35	29	2,10	34	71,4	51	107,1	63	132,3	40	84,0	80	168,0	100	210,0
50	34	2,94	14	41,6	42	123,4	52	152,8	17	49,9	50	147,0	62	182,0
70	38	3,87	13	50,3	38	147,0	47	181,8	15	58,0	44	170,2	55	212,0
95	44	5,18	10	51,8	22	113,9	27	139,8	13	67,3	39	202,0	48	248,0
120	47	6,73	9	56,9	20	126,6	25	168,2	12	75,9	24	151,9	30	201,9
150	52	7,79	8	62,3	18	140,2	22	171,3	10	77,9	22	171,3	27	210,3
185	59	9,69	7	67,8	16	155,0	20	193,8	9	87,2	20	193,8	25	242,2
240	71	13,00	4	52,0	11	143,0	13	169,0	6	78,0	14	182,0	17	221,0

## PESOS DE BANDEJAS / WEIGHTS

### BANDEJA ESCALERA LIGERA Serie BEL / LIGHT LADDER TRAY BEL Series

<b>Perfil Nº 1</b> <i>Profile Nº 1</i>		<b>Perfil Nº 2</b> <i>Profile Nº 2</i>	
<b>Ancho</b> <i>Width</i>	<b>Kg/m</b> <i>Kg/m</i>	<b>Ancho</b> <i>Width</i>	<b>Kg/m</b> <i>Kg/m</i>
600	8,1	600	9,1
500	7,6	500	8,6
400	7,0	400	8,0
300	6,6	300	7,6
200	5,0	200	5,5
100	4,3	100	4,9

Los pesos están tomados de la bandeja con altura libre de 80 mm.

*These weights correspond to 80 mm free height tray.*

### BANDEJA ESCALERA PESADA Serie BE / HEAVY LADDER TRAY BE Series

<b>Ancho</b> <i>Width</i>	<b>100/500</b>	<b>100/300</b> <b>Kg/m</b> <i>Kg/m</i>	<b>150/300</b>
910	17,3	19,9	23,9
600	15,9	17,6	21,5
460	15,2	16,6	20,5
230	14,2	14,9	18,8

### BANDEJA PERFORADA Serie BP / PERFORATED TRAY BP Series

#### **ESPESORES / THICKNESS**

<b>Ancho</b> <i>Width</i>	<b>0,8</b>	<b>1</b>	<b>1,2</b> <b>Kg/m</b> <i>Kg/m</i>	<b>1,5</b>	<b>2</b>	<b>2,5</b>
50	0,55	0,68	0,82	1,03	1,37	1,70
100	0,85	1,06	1,28	1,60	2,13	2,60
200	1,48	1,85	2,22	2,77	3,70	4,60
400	2,73	3,42	4,10	4,79	6,38	8,50

**BANDEJA PERFORADA Serie BP / *PERFORATED TRAY BP Series***

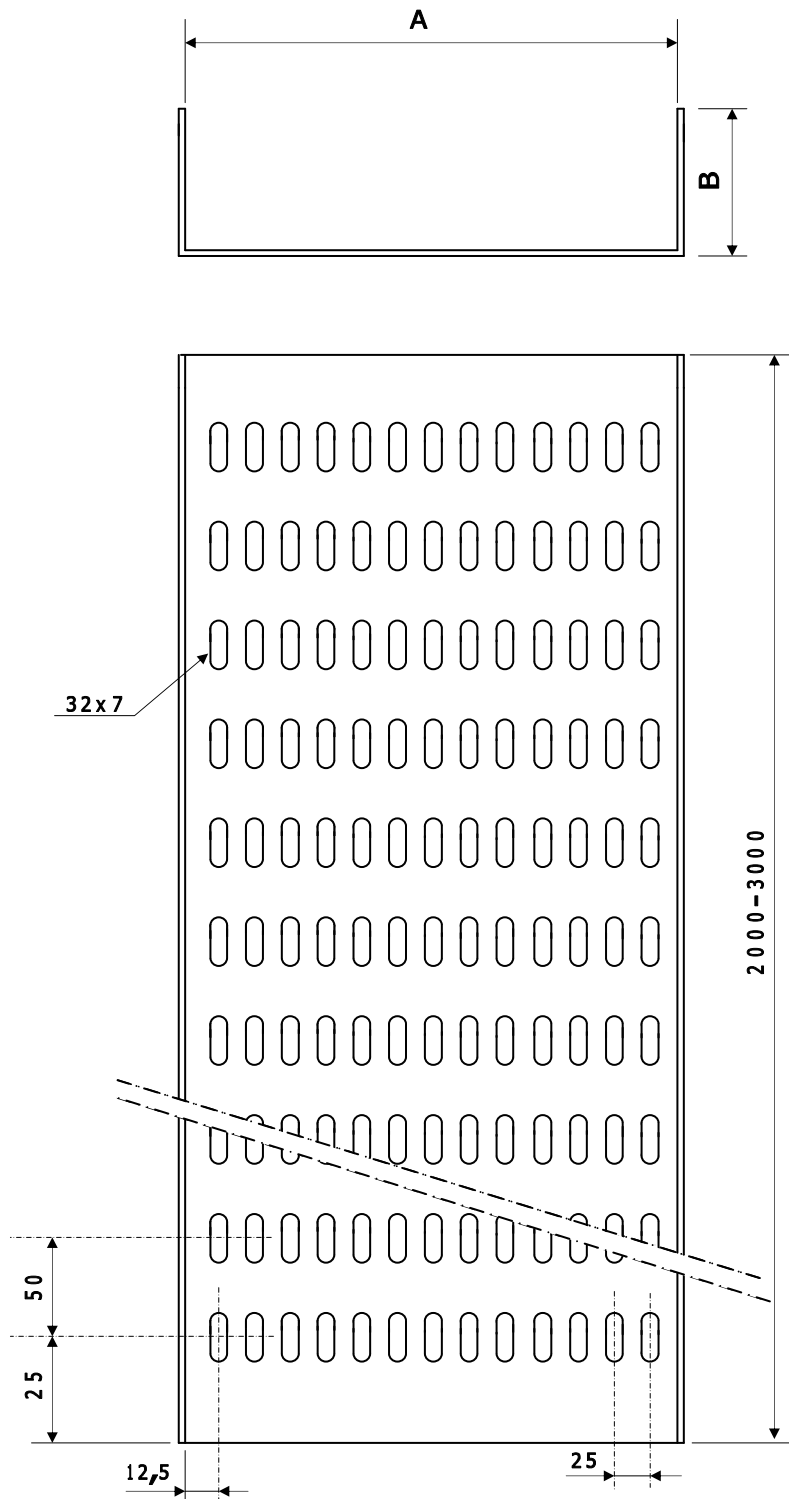

INDICAR ESPESOR Y ACABADO  
*INDICATE THICKNESS AND FINISH*

Nota: Se puede fabricar en otros anchos y alturas de ala

*Note: it can be manufactured in others widths and heights of wing*

**Espesores: 1,5 - 2 - 2,5 - 3 mm**  
*Thickness: 1,5 - 2 - 2,5 - 3 mm*

REFERENCIA <i>REFERENCE</i>	BP-50	BP-100	BP-150	BP-200	BP-250	BP-300	BP-400	BP-500	BP-600
A	50	100	150	200	250	300	400	500	600
B	15	15	25	25	25	50	50	50	50

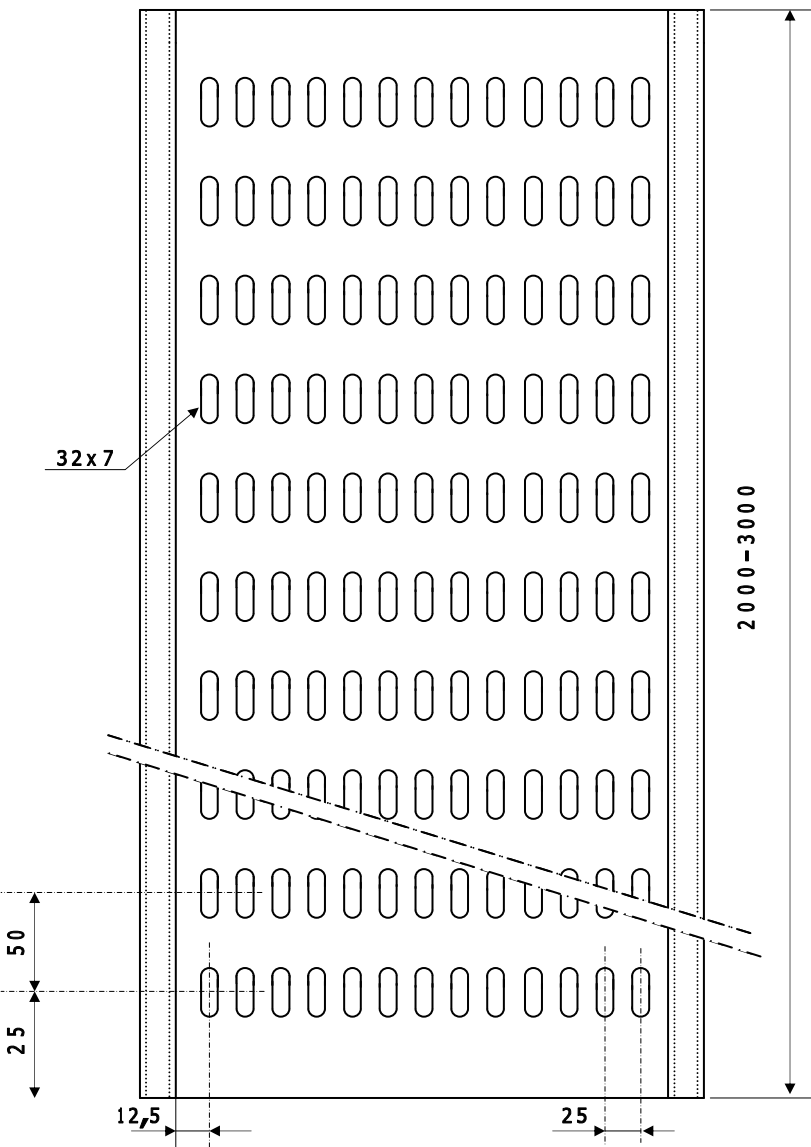
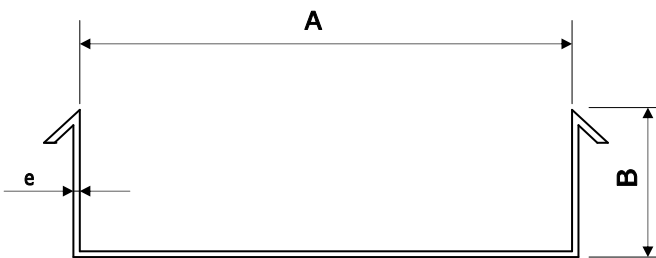

INDICAR ESPESOR Y ACABADO  
*INDICATE THICKNESS AND FINISH*

Nota: Se puede fabricar en otros anchos y alturas de ala

*Note: it can be manufactured in others widths and heights of wing*

**Espesores: 2 - 2,5 - 3 mm**  
*Thickness: 2 - 2,5 - 3 mm*

REFERENCIA <i>REFERENCE</i>	BPV-50	BPV-100	BPV-150	BPV-200	BPV-250	BPV-300	BPV-400	BPV-500	BPV-600
A	50	100	150	200	250	300	400	500	600
B	30	30	30	50	50	50	50	50	50

**CODO HORIZONTAL 90° Serie CH / *HORIZONTAL ELBOW 90° CH Series***

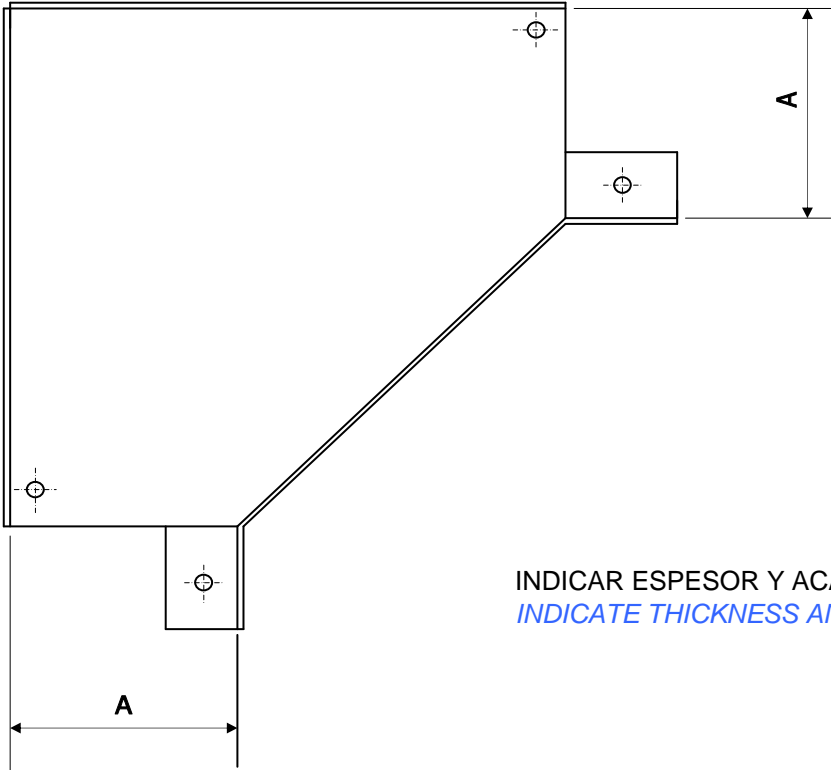
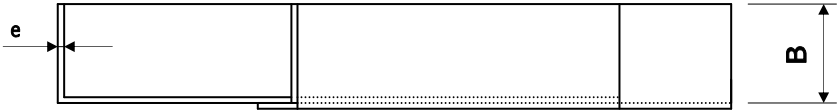

**Espesores: 1,5 - 2 - 2,5 - 3 mm**  
*Thickness: 1,5 - 2 - 2,5 - 3 mm*

REFERENCIA <i>REFERENCE</i>	CH-50	CH-100	CH-150	CH-200	CH-250	CH-300	CH-400	CH-500	CH-600
A	50	100	150	200	250	300	400	500	600
B	15-30	15-30	25-30	25-50	25-50	50	50	50	50

## DERIVACION EN TE Serie TE / TES TE Series

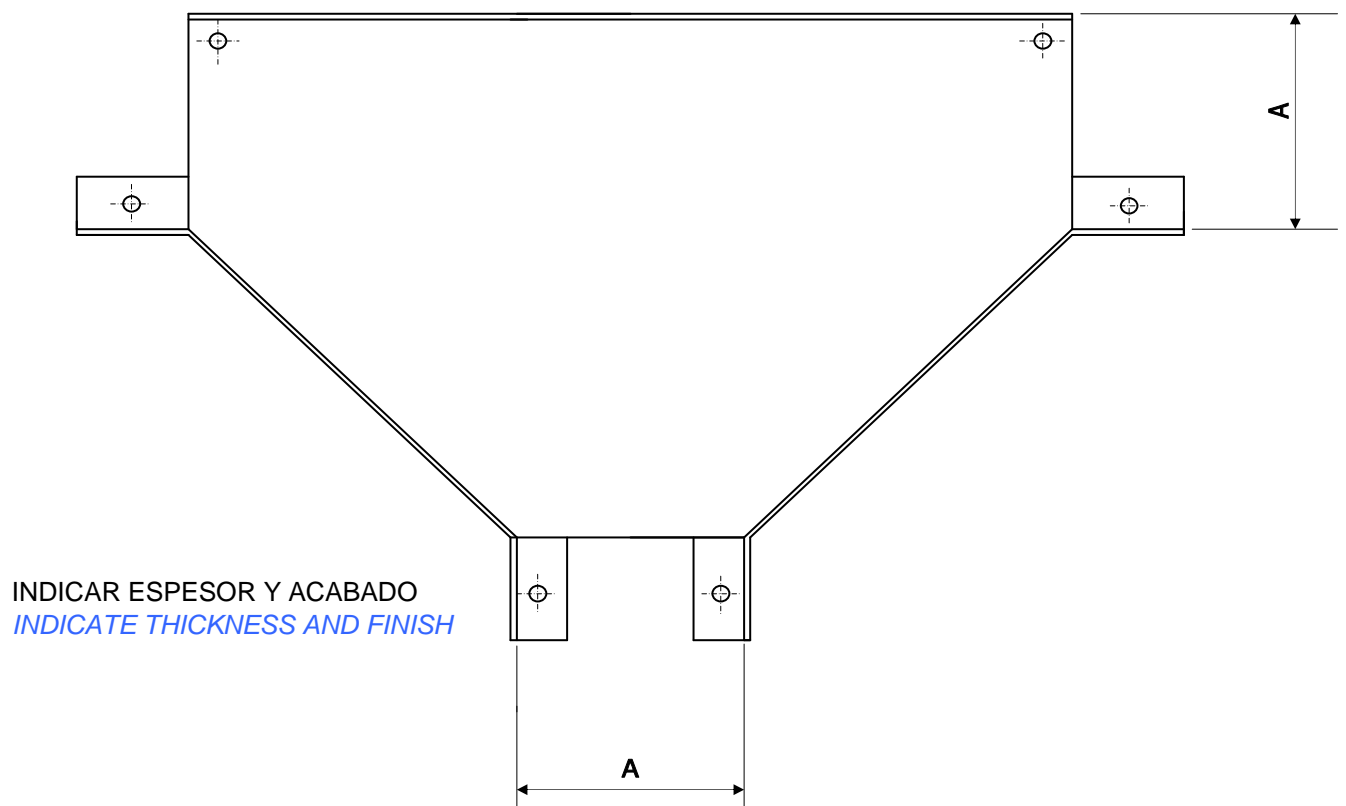
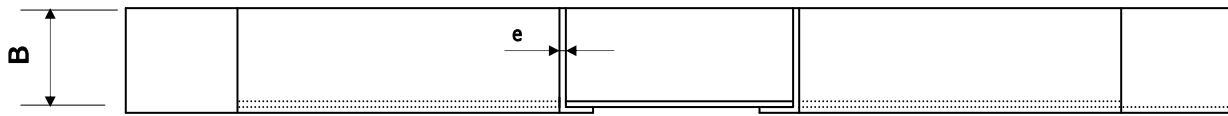

**Espesores: 1,5 - 2 - 2,5 - 3 mm**  
**Thickness: 1,5 - 2 - 2,5 - 3 mm**

REFERENCIA <i>REFERENCE</i>	TE-50	TE-100	TE-150	TE-200	TE-250	TE-300	TE-400	TE-500	TE-600
A	50	100	150	200	250	300	400	500	600
B	15-30	15-30	25-30	25-50	25-50	50	50	50	50

**CODO CONVEXO 90° Serie CX / CONVEX ELBOW 90° CX Series**

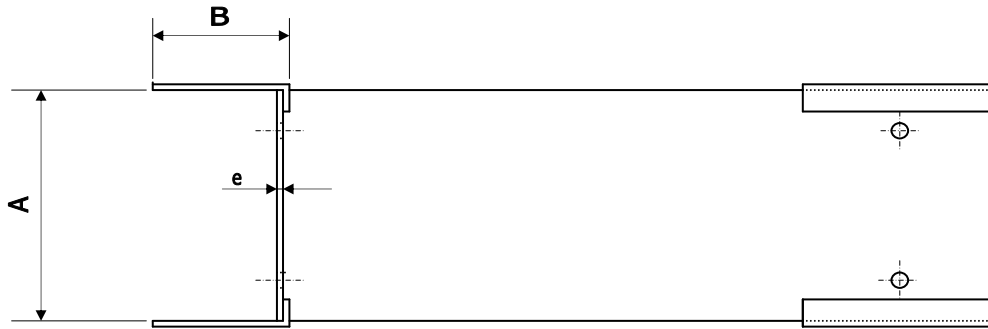

INDICAR ESPESOR Y ACABADO  
 INDICATE THICKNESS AND FINISH

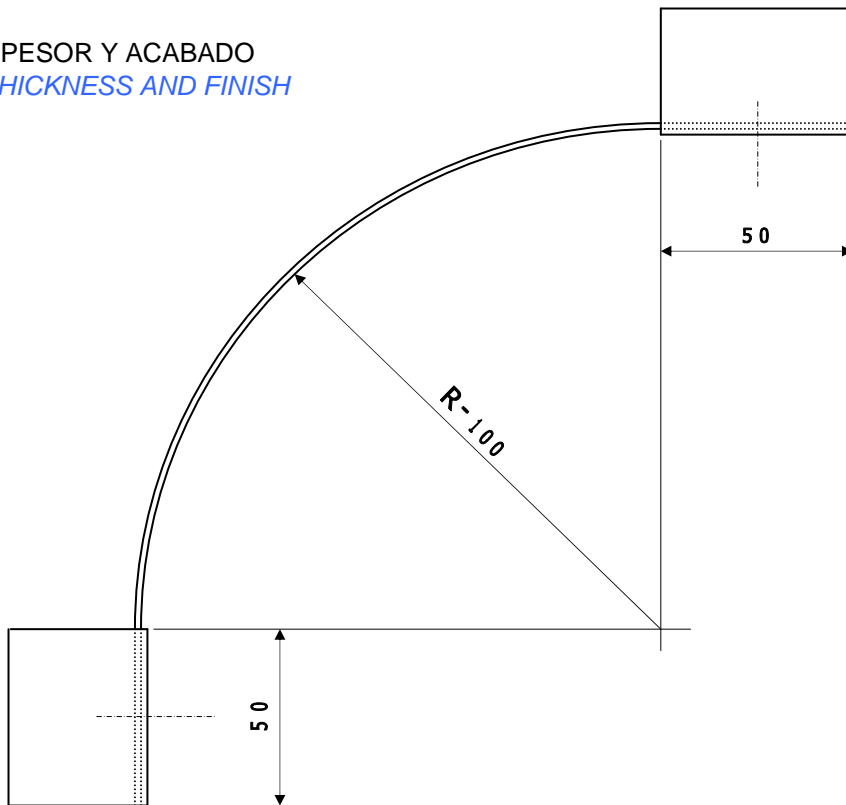

**Espesores: 1,5 - 2 - 2,5 - 3 mm**  
**Thickness: 1,5 - 2 - 2,5 - 3 mm**

REFERENCIA <i>REFERENCE</i>	CX-50	CX-100	CX-150	CX-200	CX-250	CX-300	CX-400	CX-500	CX-600
A	50	100	150	200	250	300	400	500	600
B	15-30	15-30	25-30	25-50	25-50	50	50	50	50

**CODO CONCAVO 90° Serie CC / *CONCAVE ELBOW 90° CC Series***

INDICAR ESPESOR Y ACABADO  
*INDICATE THICKNESS AND FINISH*

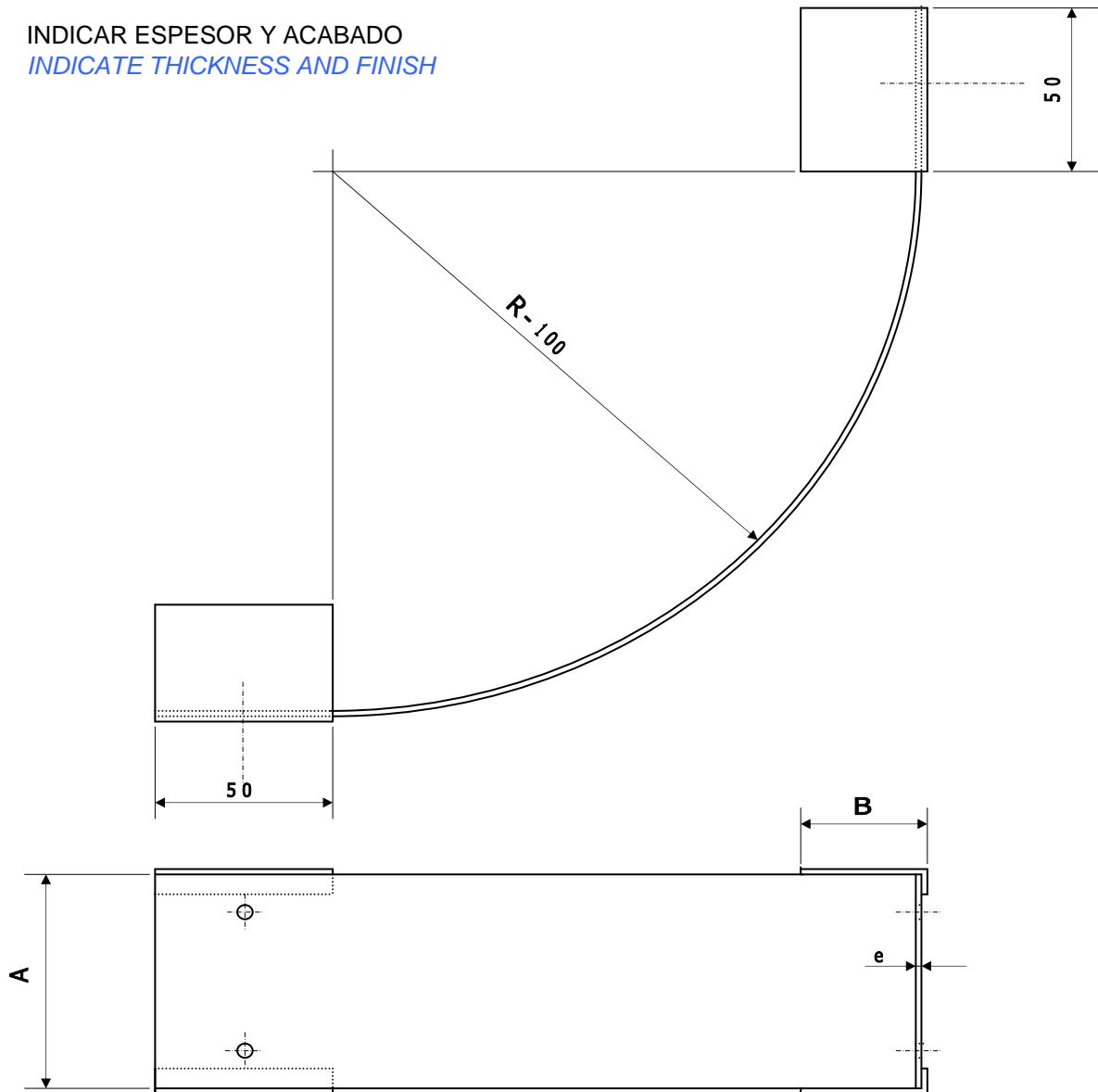

**Espesores: 1,5 - 2 - 2,5 - 3 mm**  
*Thickness: 1,5 - 2 - 2,5 - 3 mm*

REFERENCIA <i>REFERENCE</i>	CC-50	CC-100	CC-150	CC-200	CC-250	CC-300	CC-400	CC-500	CC-600
A	50	100	150	200	250	300	400	500	600
B	15-30	15-30	25-30	25-50	25-50	50	50	50	50



**DERIVACION EN CRUZ Serie X / *CROSS X Series***

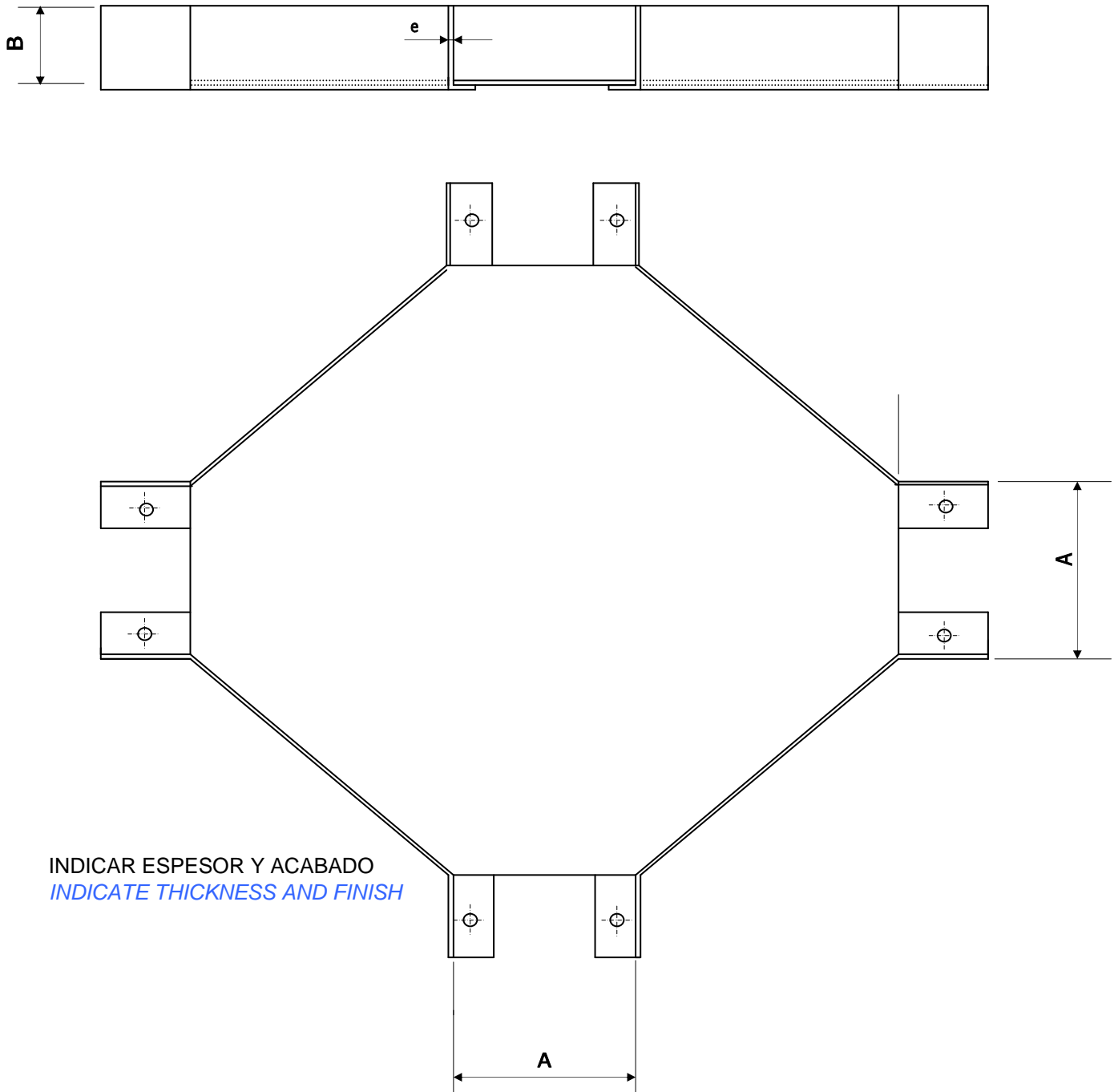

**Espesores: 1,5 - 2 - 2,5 - 3 mm**  
*Thickness: 1,5 - 2 - 2,5 - 3 mm*

REFERENCIA <i>REFERENCE</i>	X-50	X-100	X-150	X-200	X-250	X-300	X-400	X-500	X-600
A	50	100	150	200	250	300	400	500	600
B	15-30	15-30	25-30	25-50	25-50	50	50	50	50

**UNION DE BANDEJA PERFORADA / *JOINT OF PERFORATED TRAY***

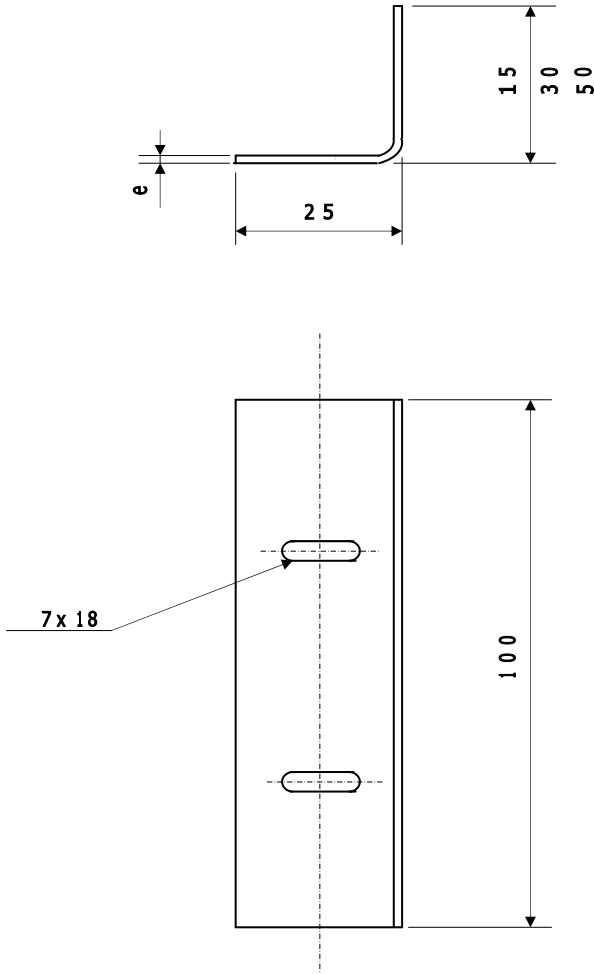

INDICAR ESPESOR Y ACABADO  
*INDICATE THICKNESS AND FINISH*

LA TORNILLERIA PUEDE SER ELECTROCINCADA o INOXIDABLE  
*BOLT, NUT AND WASHER CAN BE ELECTROLYTIC OR STAINLESS*

**TAPAS DE BANDEJA PERFORADA / *PERFORATED AND BLIND COVER***

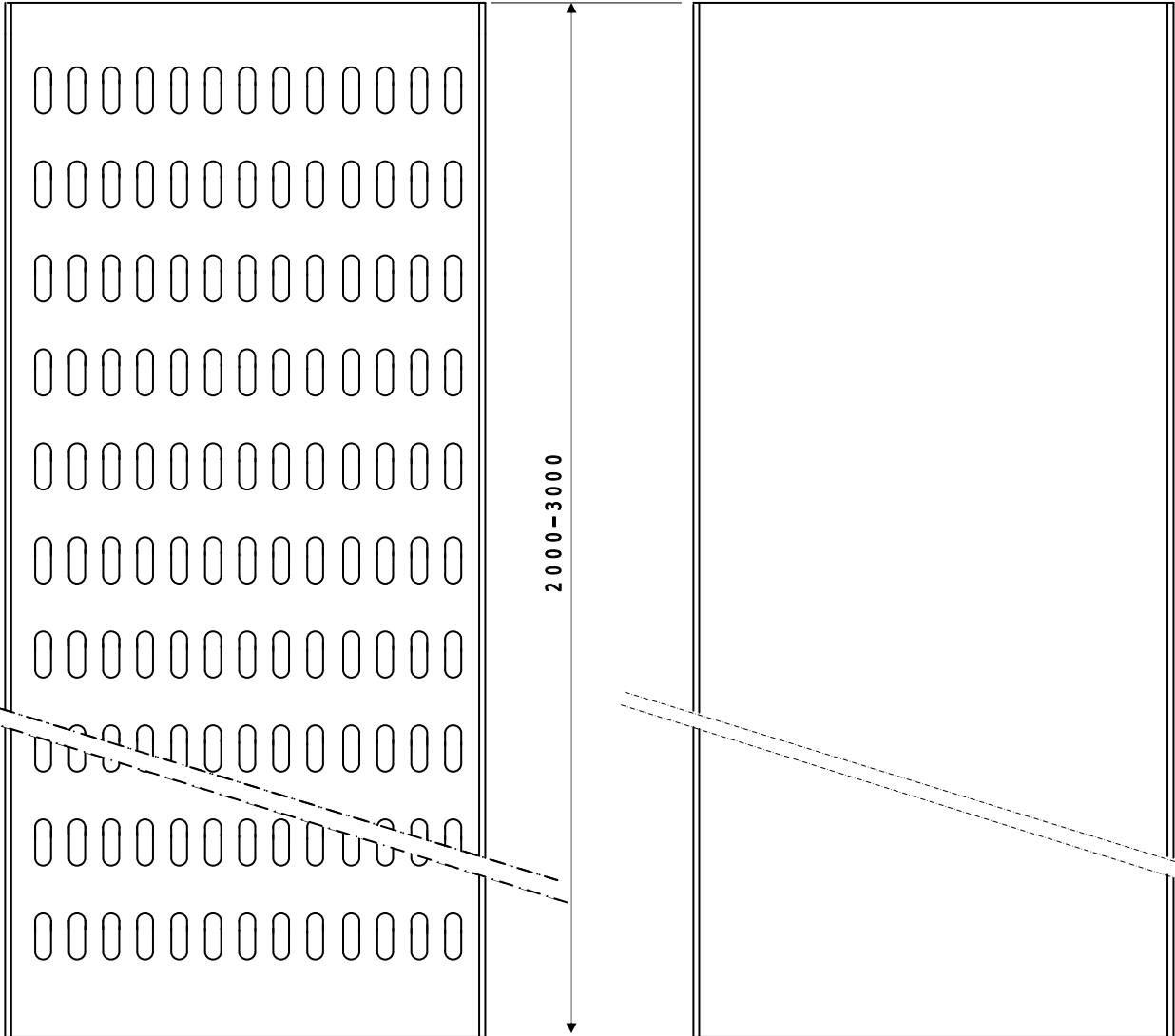

TAPA PERFORADA  
*PERFORATED COVER*

TAPA CIEGA  
*BLIND COVER*

INDICAR ESPESOR ANCHO Y ACABADO  
*INDICATE THICKNESS WIDE AND FINISH*

## BANDEJA ESCALERA Serie BEL / *LADDER TRAY BEL Series*

PERFIL LARGUERO  
*JAMB PROFILE*

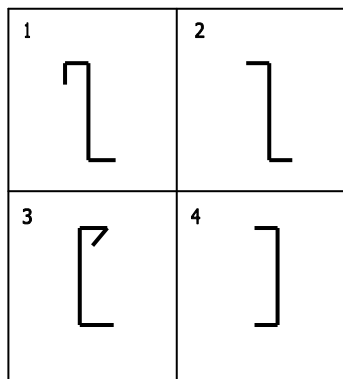

PERFIL TRAVESAÑO  
*TRANSOM PROFILE*

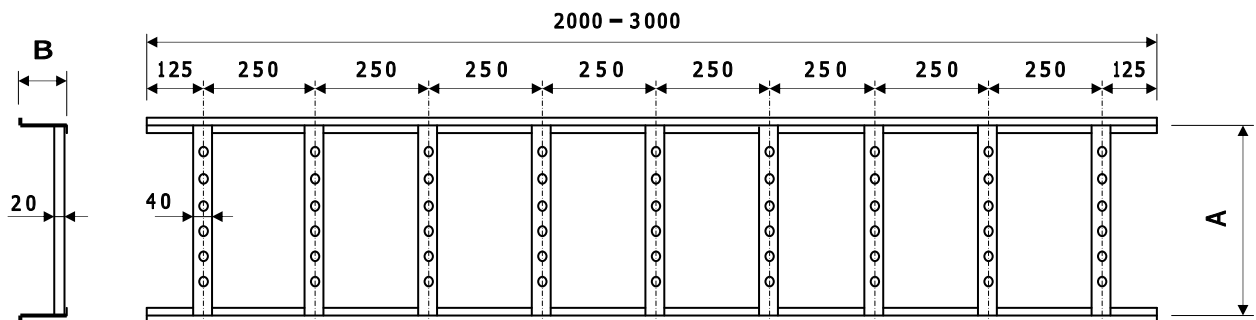
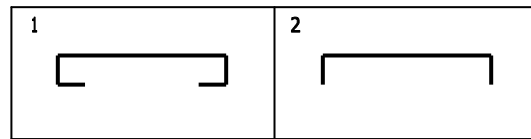

NOTA: La unión de travesaños y largueros se efectúa por soldadura continua CO<sub>2</sub>, y un electrodo especial con un coeficiente de alargamiento del 20%, lo que posibilita una estructura firme y elástica al mismo tiempo

*NOTE: The joint of transoms and jamps is made by CO<sub>2</sub> continuous welding and one special electrode with a 20% of elongation to facilitate both a steady and elastic structure.*

REF.	BEL 0	BEL 1	BEL 2	BEL 3	BEL 4	BEL 5	BEL 6
A	100	200	300	400	500	600	700
B	72	72	72	72	72	72	72

REF.	BEL 10	BEL 11	BEL 12	BEL 13	BEL 14	BEL 15	BEL 16
A	100	200	300	400	500	600	700
B	102	102	102	102	102	102	102

REF.	BEL 20	BEL 21	BEL 22	BEL 23	BEL 24	BEL 25	BEL 26
A	100	200	300	400	500	600	700
B	122	122	122	122	122	122	122

La unión entre travesaños y accesorios se efectúa por medio de la placa BE-P

*The joint between transoms and fittings is made by one BE-P plate.*

Indicar en la referencia el perfil escogido, espesor y el acabado de la bandeja.

*Indicate, in the reference, the chosen profile, thickness and the finish of the tray.*

**CODO HORIZONTAL Serie BEL / *HORIZONTAL ELBOW TRAY BEL Series***

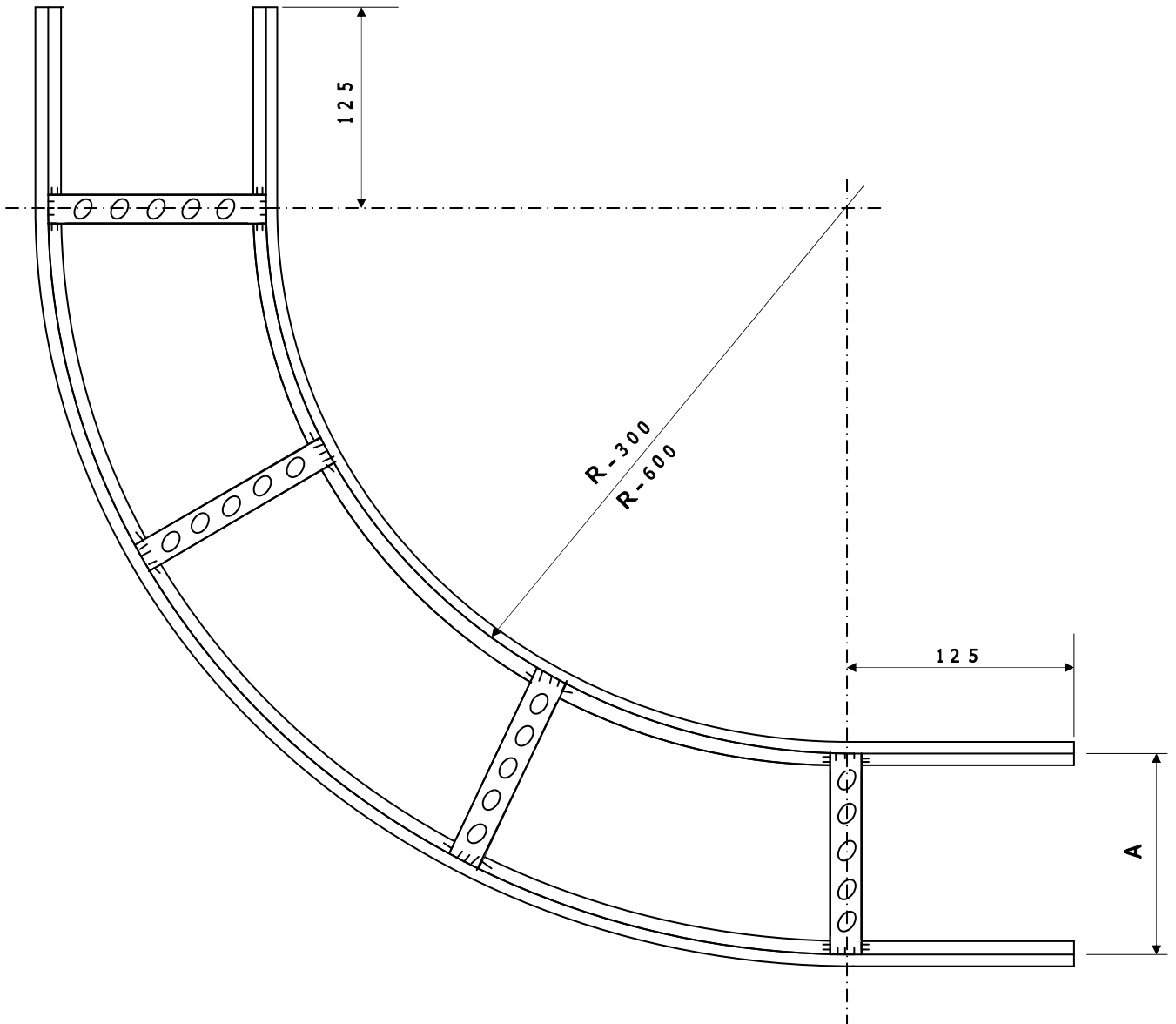

REF.	BEL-C 0	BEL-C 1	BEL-C 2	BEL-C 3	BEL-C 4	BEL-C 5	BEL-C 6
<b>A</b>	100	200	300	400	500	600	700
<b>B</b>	72	72	72	72	72	72	72

REF.	BEL-C 10	BEL-C 11	BEL-C 12	BEL-C 13	BEL-C 14	BEL-C 15	BEL-C 16
<b>A</b>	100	200	300	400	500	600	700
<b>B</b>	102	102	102	102	102	102	102

  

REF.	BEL-C 20	BEL-C 21	BEL-C 22	BEL-C 23	BEL-C 24	BEL-C 25	BEL-C 26
<b>A</b>	100	200	300	400	500	600	700
<b>B</b>	122	122	122	122	122	122	122

NOTA: Indicar los grados del codo (90° - 60° - 45°), así acabado de la pieza.

*NOTE: Indicate the degrees of the elbow (90° - 60° - 45°) and the piece finish as well.*

**CODO CONCAVO Serie BEL / *CONCAVE ELBOW TRAY BEL Series***

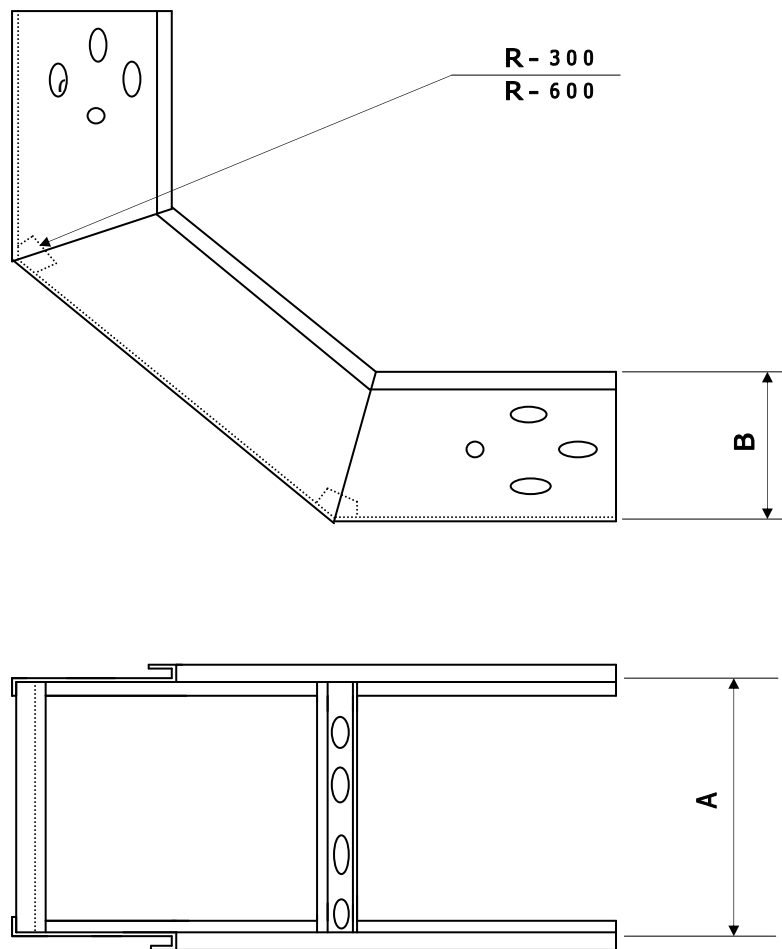

REF.	BEL-CC 0	BEL-CC 1	BEL-CC 2	BEL-CC 3	BEL-CC 4	BEL-CC 5	BEL-CC 6
<b>A</b>	100	200	300	400	500	600	700
<b>B</b>	72	72	72	72	72	72	72

REF.	BEL-CC 10	BEL-CC 11	BEL-CC 12	BEL-CC 13	BEL-CC 14	BEL-CC 15	BEL-CC 16
<b>A</b>	100	200	300	400	500	600	700
<b>B</b>	102	102	102	102	102	102	102

REF.	BEL-CC 20	BEL-CC 21	BEL-CC 22	BEL-CC 23	BEL-CC 24	BEL-CC 25	BEL-CC 26
<b>A</b>	100	200	300	400	500	600	700
<b>B</b>	122	122	122	122	122	122	122

NOTA: Indicar los grados del codo (90° - 60° - 45°), así acabado de la pieza.

*NOTE: Indicate the degrees of the elbow (90° - 60° - 45°) and the piece finish as well.*

**CODO CONVEXO Serie BEL / *CONVEX ELBOW TRAY BEL Series***

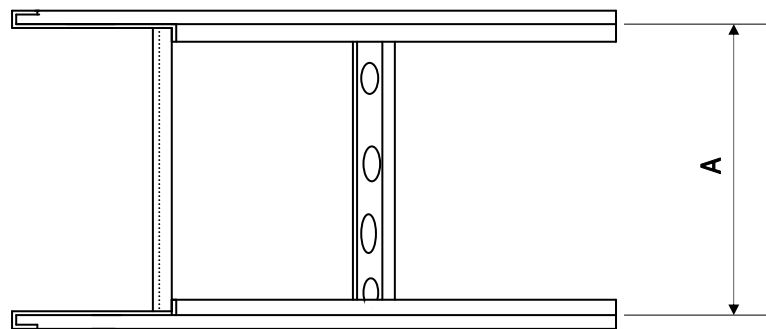
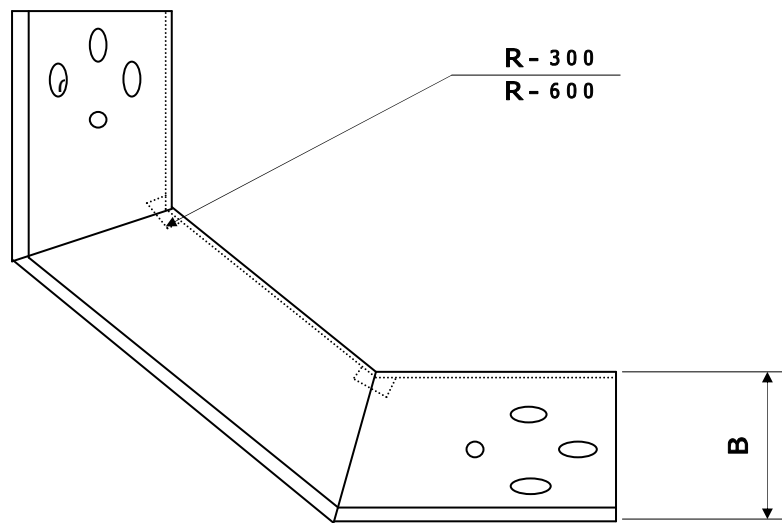

REF.	BEL-CX 0	BEL-CX 1	BEL-CX 2	BEL-CX 3	BEL-CX 4	BEL-CX 5	BEL-CX 6
<b>A</b>	100	200	300	400	500	600	700
<b>B</b>	72	72	72	72	72	72	72

REF.	BEL-CX 10	BEL-CX 11	BEL-CX 12	BEL-CX 13	BEL-CX 14	BEL-CX 15	BEL-CX 16
<b>A</b>	100	200	300	400	500	600	700
<b>B</b>	102	102	102	102	102	102	102

REF.	BEL-CX 20	BEL-CX 21	BEL-CX 22	BEL-CX 23	BEL-CX 24	BEL-CX 25	BEL-CX 26
<b>A</b>	100	200	300	400	500	600	700
<b>B</b>	122	122	122	122	122	122	122

NOTA: Indicar los grados del codo (90° - 60° - 45°), así acabado de la pieza.

*NOTE: Indicate the degrees of the elbow (90° - 60° - 45°) and the piece finish as well.*

**DERIVACION EN TE Serie BEL / *TE BRANCHING TRAY BEL Series***

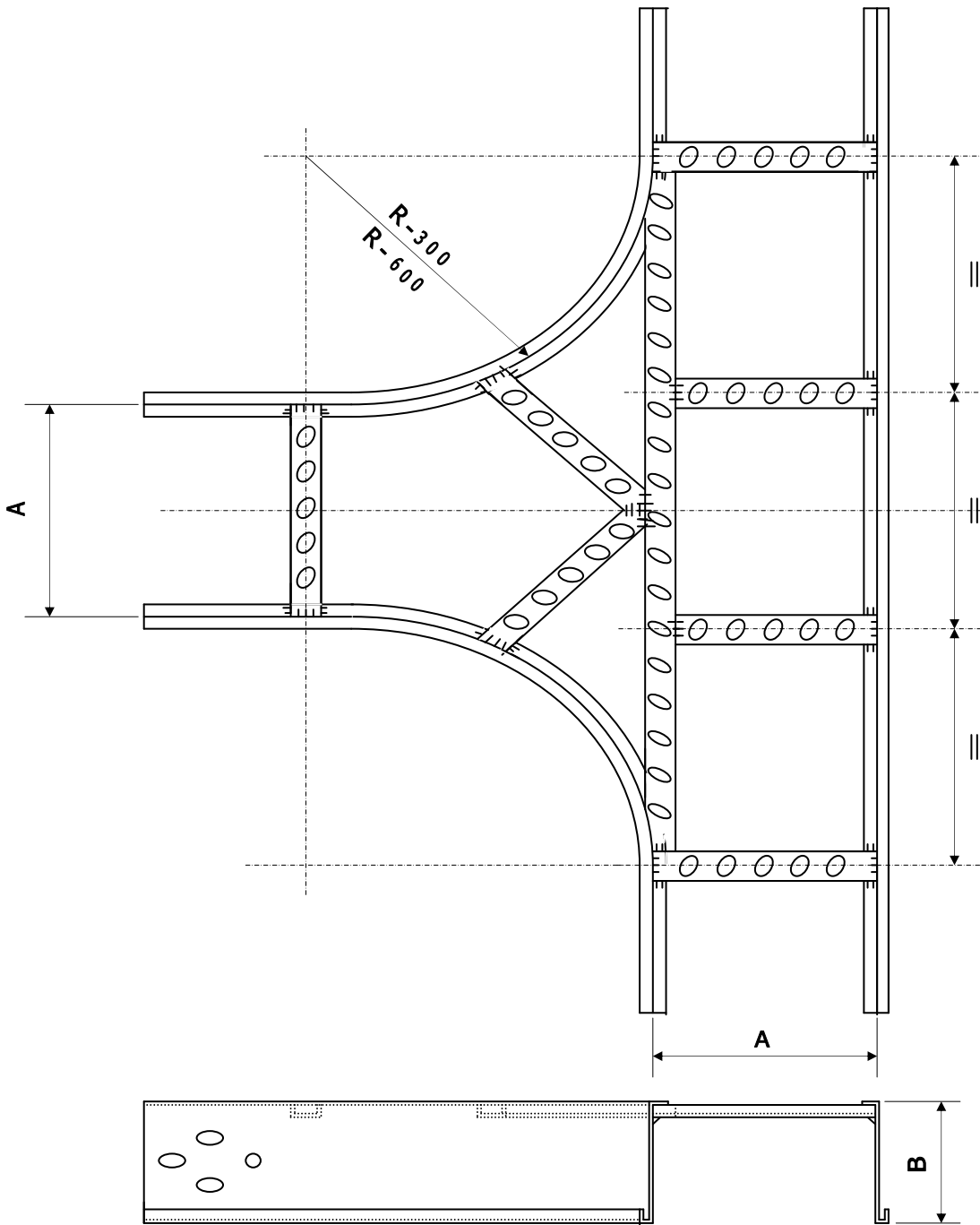

<b>REF.</b>	<b>BEL-T 0</b>	<b>BEL-T 1</b>	<b>BEL-T 2</b>	<b>BEL-T 3</b>	<b>BEL-T 4</b>	<b>BEL-T 5</b>	<b>BEL-T 6</b>
<b>A</b>	100	200	300	400	500	600	700
<b>B</b>	72	72	72	72	72	72	72
<b>REF.</b>	<b>BEL-T 10</b>	<b>BEL-T 11</b>	<b>BEL-T 12</b>	<b>BEL-T 13</b>	<b>BEL-T 14</b>	<b>BEL-T 15</b>	<b>BEL-T 16</b>
<b>A</b>	100	200	300	400	500	600	700
<b>B</b>	102	102	102	102	102	102	102
<b>REF.</b>	<b>BEL-T 20</b>	<b>BEL-T 21</b>	<b>BEL-T 22</b>	<b>BEL-T 23</b>	<b>BEL-T 24</b>	<b>BEL-T 25</b>	<b>BEL-T 26</b>
<b>A</b>	100	200	300	400	500	600	700
<b>B</b>	122	122	122	122	122	122	122

NOTA: Indicar acabado de la pieza.

*NOTE: Indicate the finish of the piece.*



**DERIVACION EN CRUZ Serie BEL / CROSS BRANCHING TRAY BEL Series**

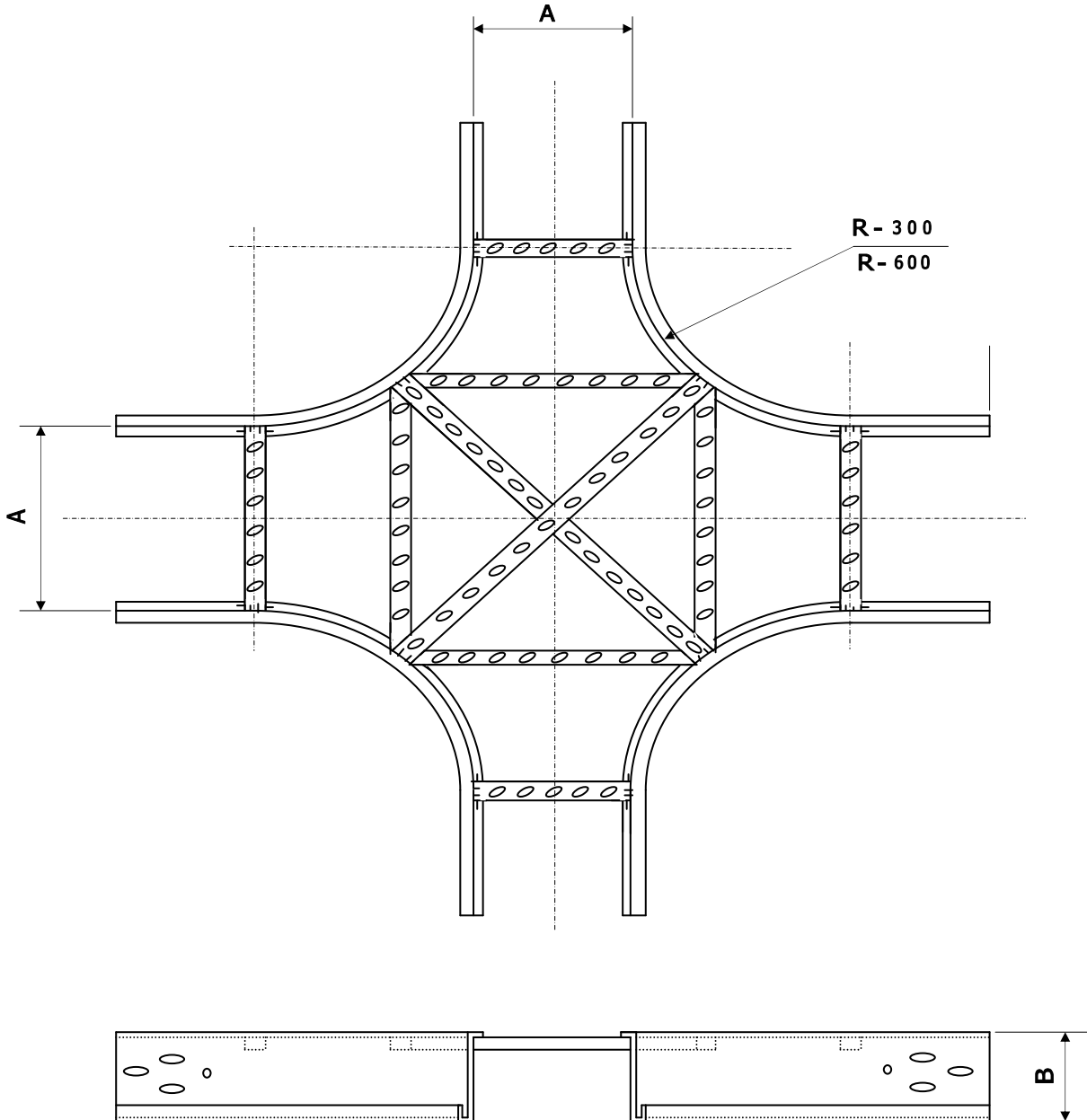

<b>REF.</b>	<b>BEL-T 0</b>	<b>BEL-T 1</b>	<b>BEL-T 2</b>	<b>BEL-T 3</b>	<b>BEL-T 4</b>	<b>BEL-T 5</b>	<b>BEL-T 6</b>
<b>A</b>	100	200	300	400	500	600	700
<b>B</b>	72	72	72	72	72	72	72
<b>REF.</b>	<b>BEL-T 10</b>	<b>BEL-T 11</b>	<b>BEL-T 12</b>	<b>BEL-T 13</b>	<b>BEL-T 14</b>	<b>BEL-T 15</b>	<b>BEL-T 16</b>
<b>A</b>	100	200	300	400	500	600	700
<b>B</b>	102	102	102	102	102	102	102
<b>REF.</b>	<b>BEL-T 20</b>	<b>BEL-T 21</b>	<b>BEL-T 22</b>	<b>BEL-T 23</b>	<b>BEL-T 24</b>	<b>BEL-T 25</b>	<b>BEL-T 26</b>
<b>A</b>	100	200	300	400	500	600	700
<b>B</b>	122	122	122	122	122	122	122

NOTA: Indicar acabado de la pieza.

*NOTE: Indicate the finish of the piece.*

## REDUCCION BANDEJA Serie BEL / *REDUCING TRAY BEL Series*

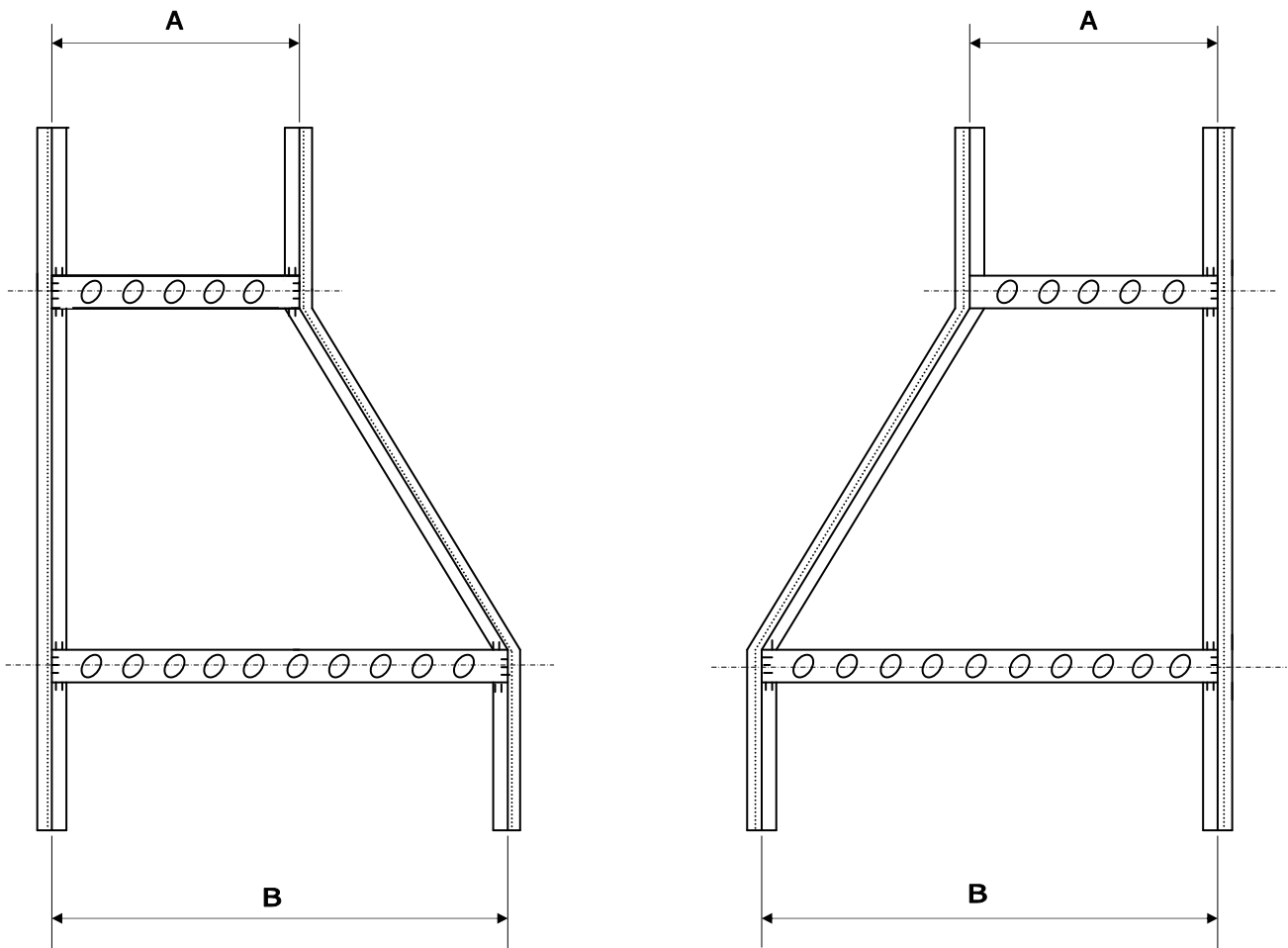

### REDUCCION A DERECHAS / *RIGHT REDUCING*

REF.	BEL-RD 0	BEL-RD 1	BEL-RD 2	BEL-RD 3	BEL-RD 4	BEL-RD 5
<b>A</b>	100	200	300	400	500	600
<b>B</b>	200	300	400	500	600	700

### REDUCCION A IZQUIERDAS / *LEFT REDUCING*

REF.	BEL-RI 0	BEL-RI 1	BEL-RI 2	BEL-RI 3	BEL-RI 4	BEL-RI 5
<b>A</b>	100	200	300	400	500	600
<b>B</b>	200	300	400	500	600	700

### REDUCCION CENTRADA / *CENTER REDUCING*

REF.	BEL-RC 0	BEL-RC 1	BEL-RC 2	BEL-RC 3	BEL-RC 4	BEL-RC 5
<b>A</b>	100	200	300	400	500	600
<b>B</b>	200	300	400	500	600	700

NOTA: Indicar acabado de la pieza.

*NOTE: Indicate the finish of the piece.*

**TAPA PARA BANDEJA Serie BEL / *COVER TRAY BEL Series***

**TAPA SENCILLA (TP)**  
*SIMPLE COVER (TP)*

**TAPA TEJADILLO (TJ)**  
*COVER TOP (TJ)*

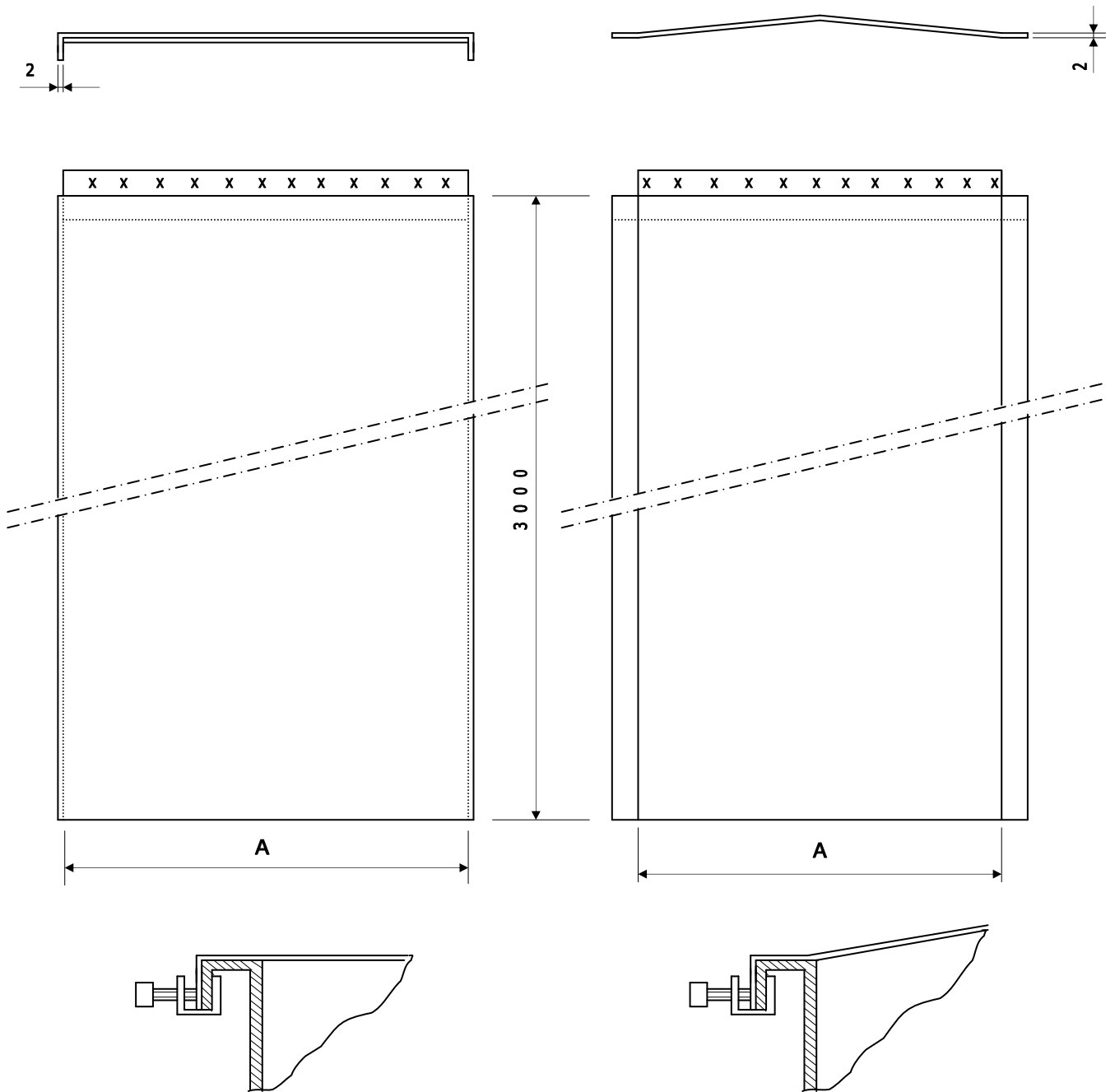

REF.	BEL-TP 0	BEL-TP 1	BEL-TP 2	BEL-TP 3	BEL-TP 4	BEL-TP 5	BEL-TP 6
A	100	200	300	400	500	600	700
REF.	BEL-TJ 0	BEL-TJ 1	BEL-TJ 2	BEL-TJ 3	BEL-TJ 4	BEL-TJ 5	BEL-TJ 6
A	100	200	300	400	500	600	700

NOTA: Indicar acabado de la pieza.

*NOTE: Indicate the finish of the piece.*

**ACCESORIOS BANDEJA Serie BEL / [ACCESSORIES TRAY BEL Series](#)**

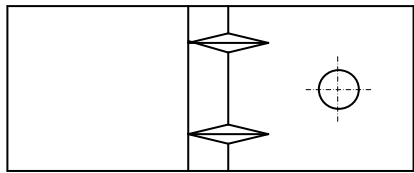
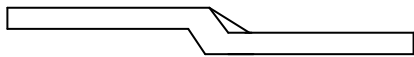

**GRAPA DE FIJACION BANDEJA**  
**REF. BEG**

[CLAMP FOR FIXING TRAY](#)  
**REF. BEG**

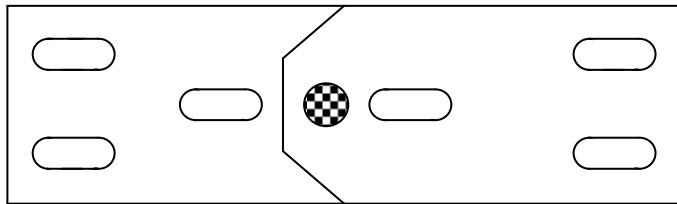

**BISAGRA**  
**REF. BEL-B**

Se suministra con 6 tornillos M-10x20 con tuercas y arandelas.

[HINGE](#)  
**REF. BEL-B**  
*Supply with 6 screws M-10x20 with nuts and washers.*

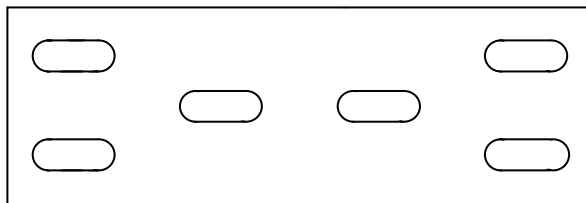

**PLACA DE UNION**  
**REF. BEL-P**

Se suministra con 6 tornillos M-10x20 con tuercas y arandelas.

[UNION PLATE](#)  
**REF. BEL-P**  
*Supply with 6 screws M-10x20 with nuts and washers.*

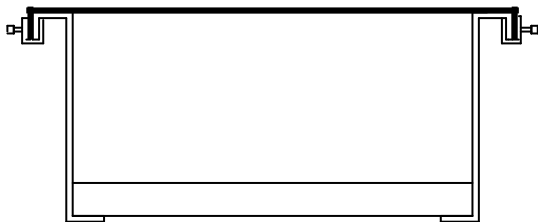

**GRAPA FIJACION DE TAPA**  
**REF. BEL-GR**

[CLAMP FOR FIXING COVER](#)  
**REF. BEL-GR**

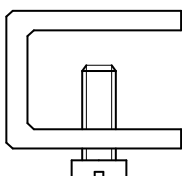

## **BANDEJA ESCALERA Serie BE / *LADDER TRAY BE Series***

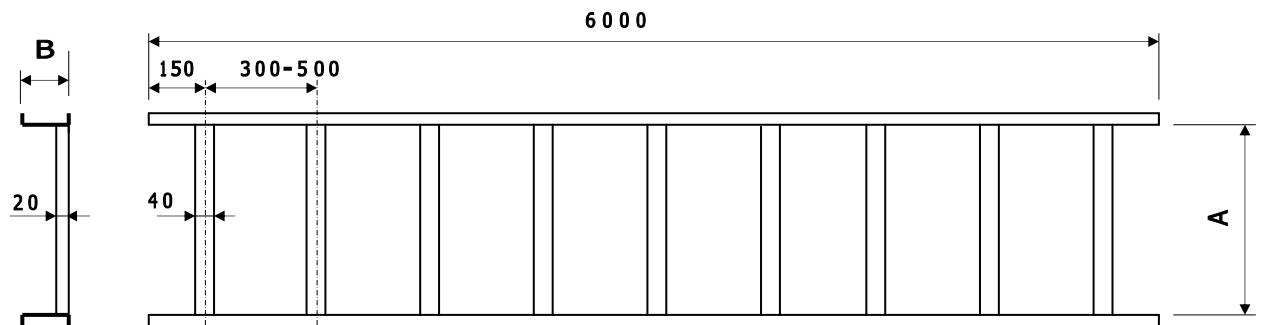

NOTA: La unión de travesaños y largueros se efectúa por soldadura continua CO<sub>2</sub>, y un electrodo especial con un coeficiente de alargamiento del 20%, lo que posibilita una estructura firme y elástica al mismo tiempo

*NOTE: The joint of transoms and jambs is made by CO<sub>2</sub> continuous welding and one special electrode with a 20% of elongation to facilitate both a steady and elastic structure.*

Espesor del larguero: 5 mm.

*Thickness of Jamb: 5 mm.*

Espesor del travesaño: 4 mm.

*Thickness of crossbars: 4 mm.*

REF.	BE 0	BE 1	BE 2	BE 3
A	230	400	600	910
B	100	100	100	100

REF.	BE 4	BE 5	BE 6	BE 7
A	230	400	600	910
B	150	150	150	150

Indicar en la referencia la separación entre travesaños, y si éstos han de ir perforados para la sujeción de los cables. Indicar acabado de la bandeja.

*Indicate, in the reference, the separation between transoms, and if they have to go perforated for the cables fastening. Indicate the finish of the tray as well.*

SE PUEDE FABRICAR CUALQUIER ANCHO DESDE 100 A 1.000 mm.

*IT CAN BE MADE IN ANY WIDTH UP 100 To 1.000 mm.*

**CODO HORIZONTAL Serie BE / *HORIZONTAL ELBOW TRAY BE Series***

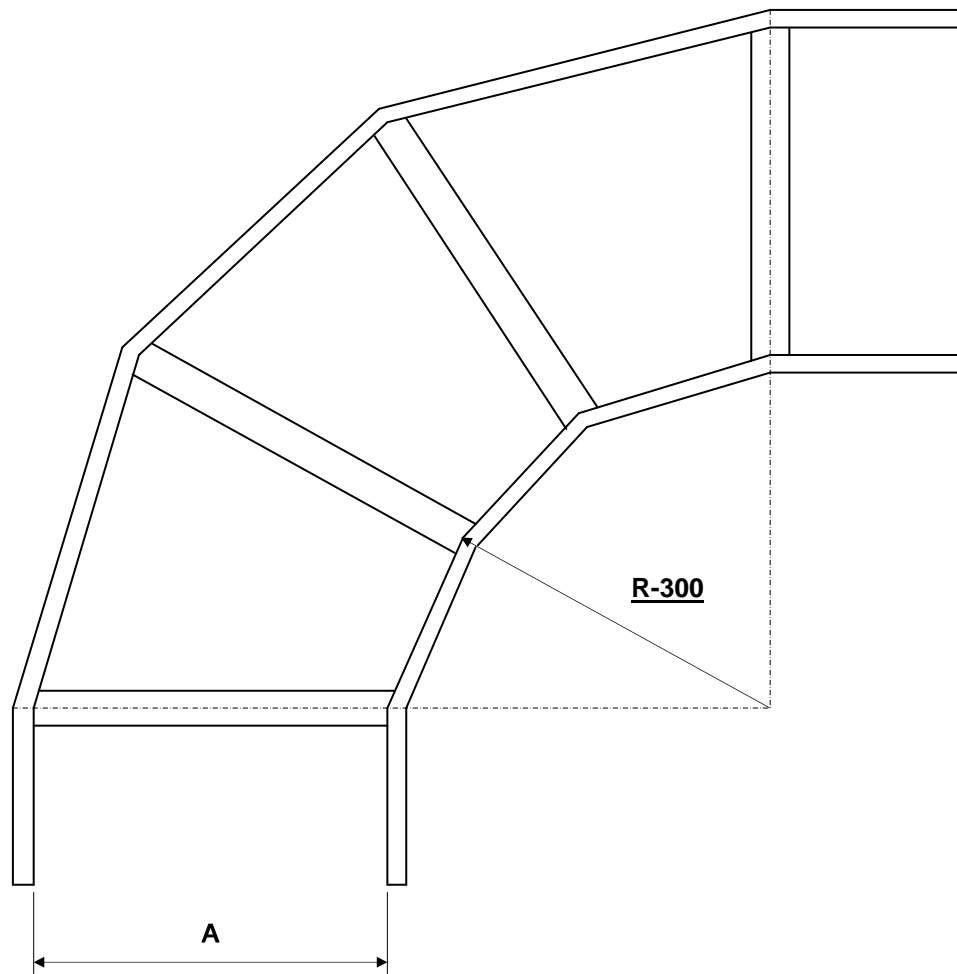
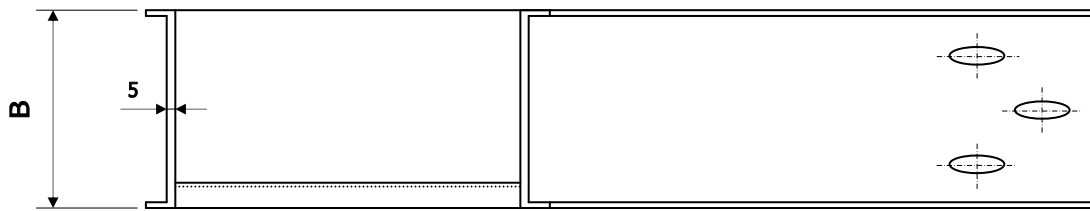

REF.	BE-C 0	BE-C 1	BE-C 2	BE-C 3
A	230	400	600	910
B	100	100	100	100

  

REF.	BE-C 4	BE-C 5	BE-C 6	BE-C 7
A	230	400	600	910
B	150	150	150	150

NOTA: Indicar los grados del codo (90° - 60° - 45°), así acabado de la pieza.

*NOTE: Indicate the degrees of the elbow (90° - 60° - 45°) and the piece finish as well.*

**CODO CONCAVO Serie BE / *CONCAVE ELBOW TRAY BE Series***

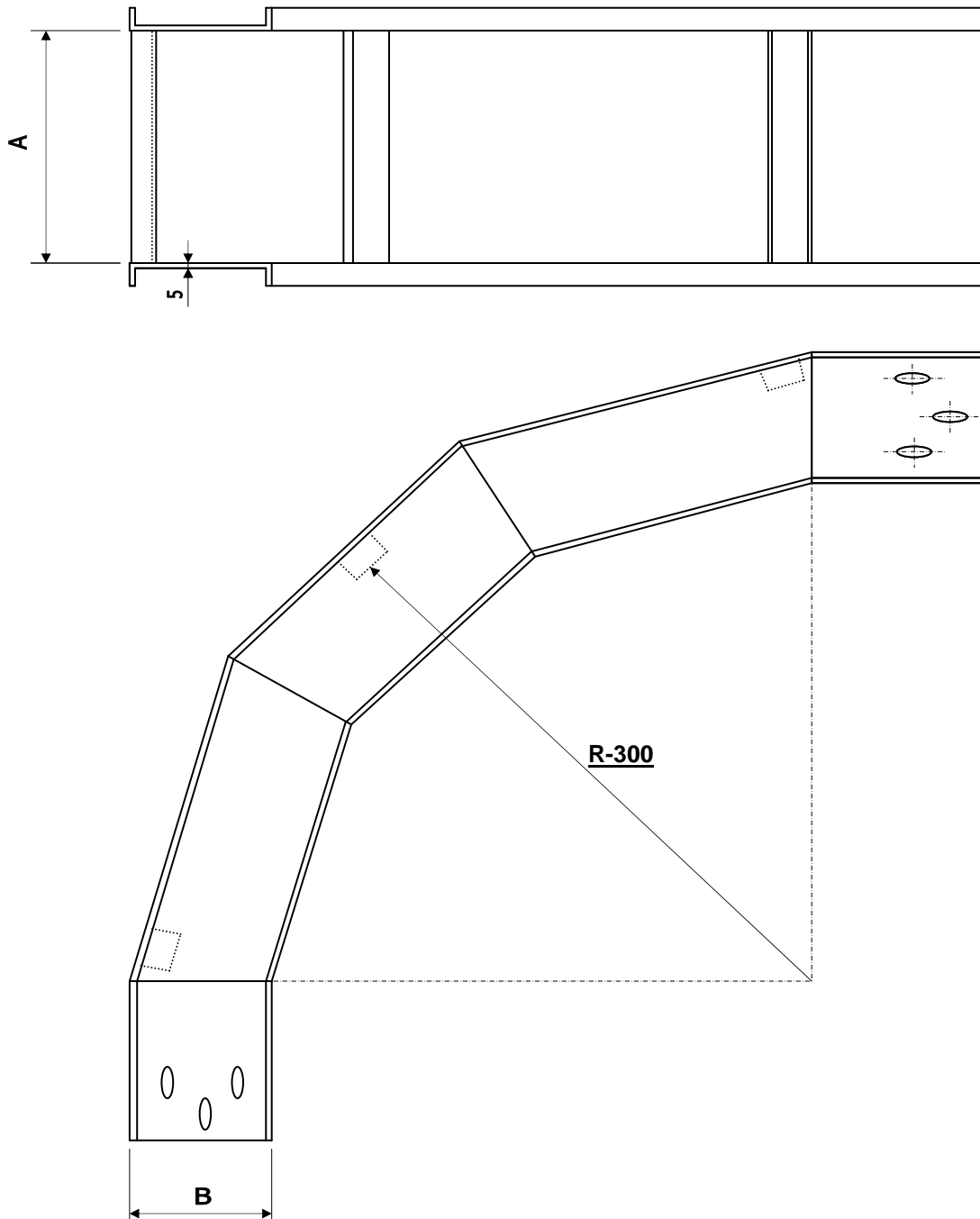

REF.	BE-CC 0	BE-CC 1	BE-CC 2	BE-CC 3
A	230	400	600	910
B	100	100	100	100

  

REF.	BE-CC 4	BE-CC 5	BE-CC 6	BE-CC 7
A	230	400	600	910
B	150	150	150	150

NOTA: Indicar los grados del codo (90° - 60° - 45°), así acabado de la pieza.

*NOTE: Indicate the degrees of the elbow (90° - 60° - 45°) and the piece finish as well.*

**CODO CONVEXO Serie BE / CONVEX ELBOW TRAY BE Series**

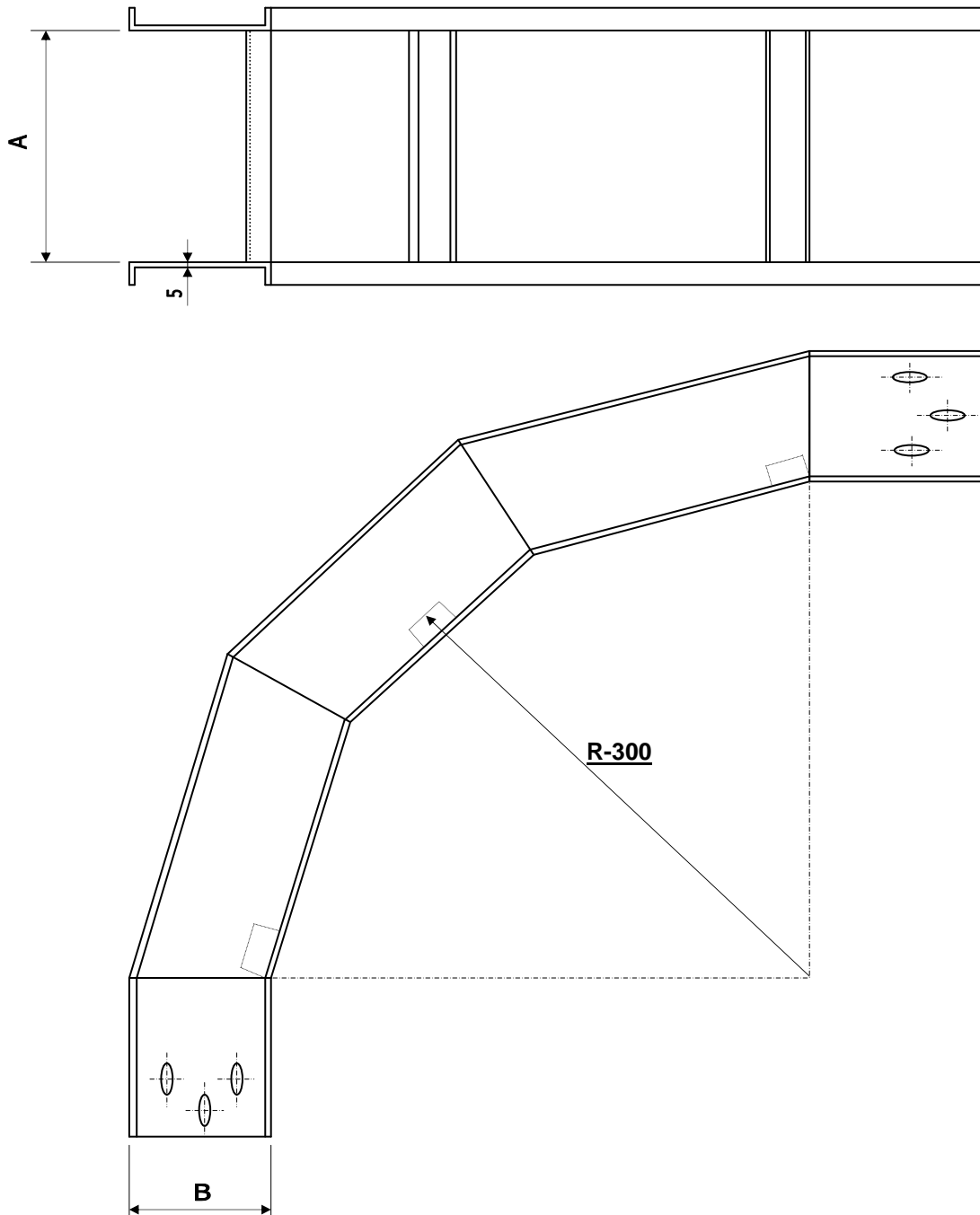

REF.	BE-CX 0	BE-CX 1	BE-CX 2	BE-CX 3
A	230	400	600	910
B	100	100	100	100

REF.	BE-CX 4	BE-CX 5	BE-CX 6	BE-CX 7
A	230	400	600	910
B	150	150	150	150

NOTA: Indicar los grados del codo (90° - 60° - 45°), así acabado de la pieza.

*NOTE: Indicate the degrees of the elbow (90° - 60° - 45°) and the piece finish as well.*



**DERIVACION EN TE Serie BE / *TE BRANCHING TRAY BE Series***

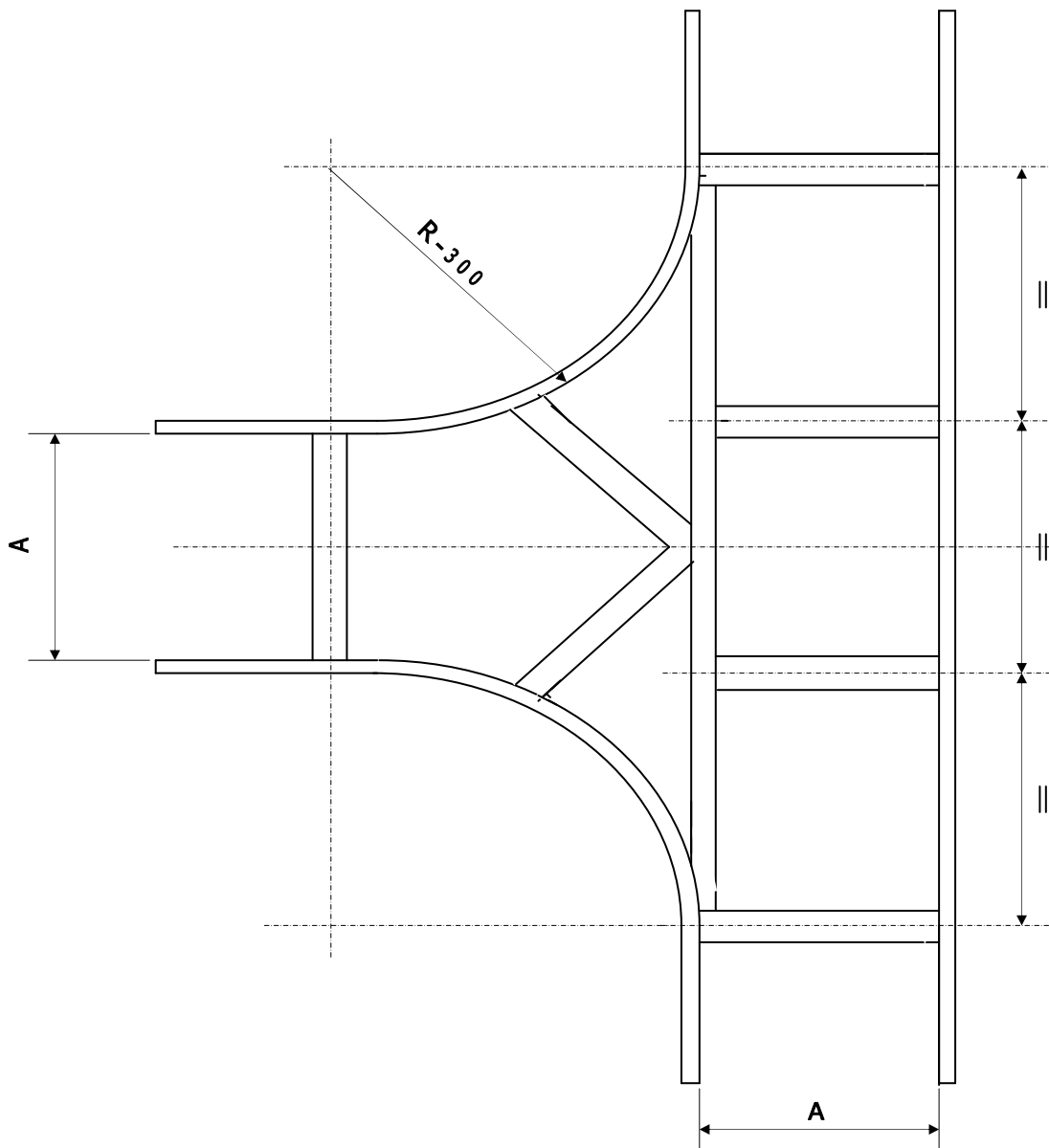

REF.	BE-T 0	BE-T 1	BE-T 2	BE-T 3
A	230	400	600	910
B	100	100	100	100

  

REF.	BE-T 4	BE-T 5	BE-T 6	BE-T 7
A	230	400	600	910
B	150	150	150	150

NOTA: Indicar acabado de la pieza.

*NOTE: Indicate this finish of the piece.*

**DERIVACION EN CRUZ Serie BE / *CROSS BRANCHING TRAY BE Series***

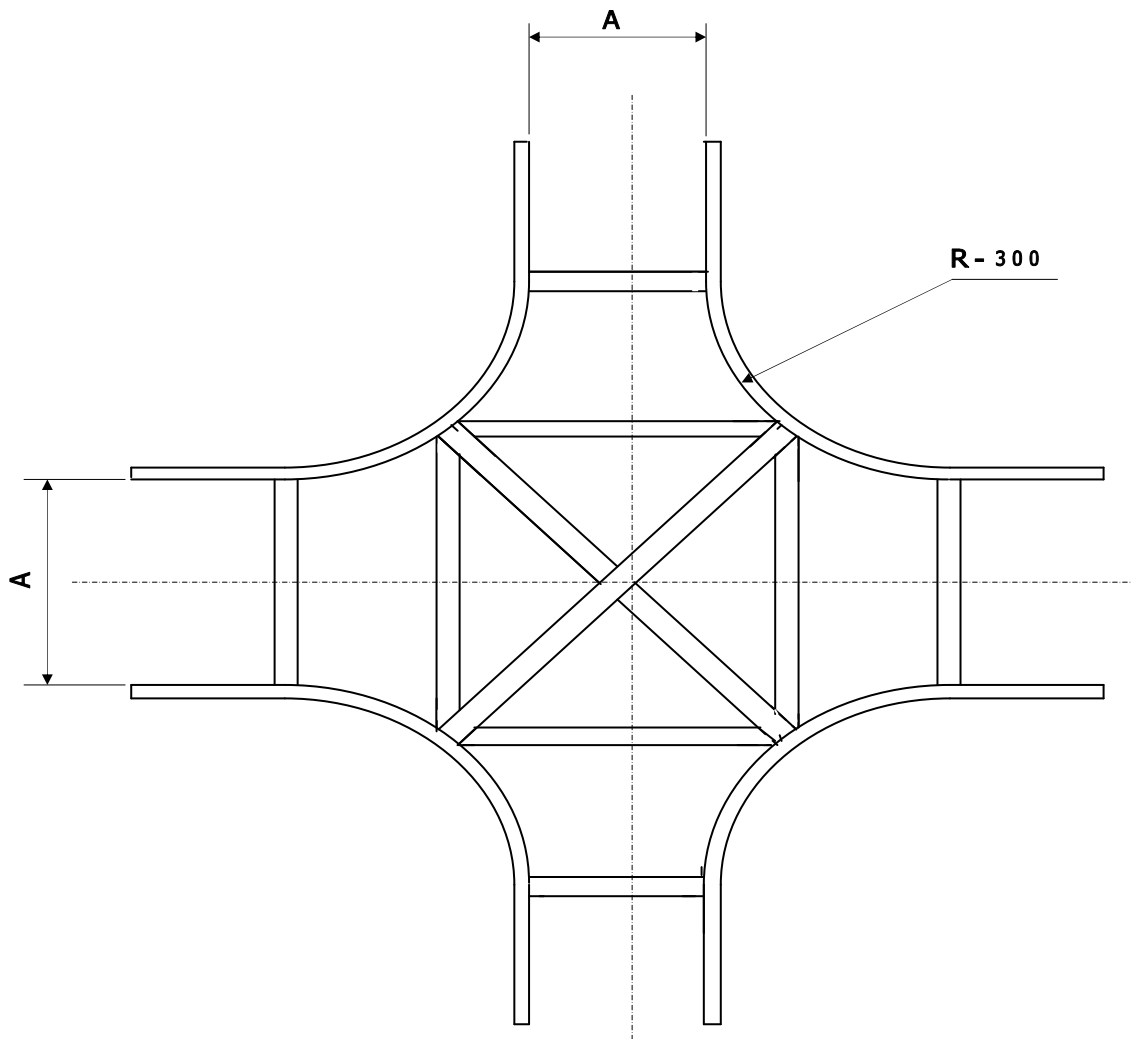

REF.	BE-CZ 0	BE-CZ 1	BE-CZ 2	BE-CZ 3
A	230	400	600	910
B	100	100	100	100

  

REF.	BE-CZ 4	BE-CZ 5	BE-CZ 6	BE-CZ 7
A	230	400	600	910
B	150	150	150	150

NOTA: Indicar acabado de la pieza.

*NOTE: Indicate this finish of the piece.*

## **REDUCCION BANDEJA Serie BE / *REDUCING TRAY BE Series***

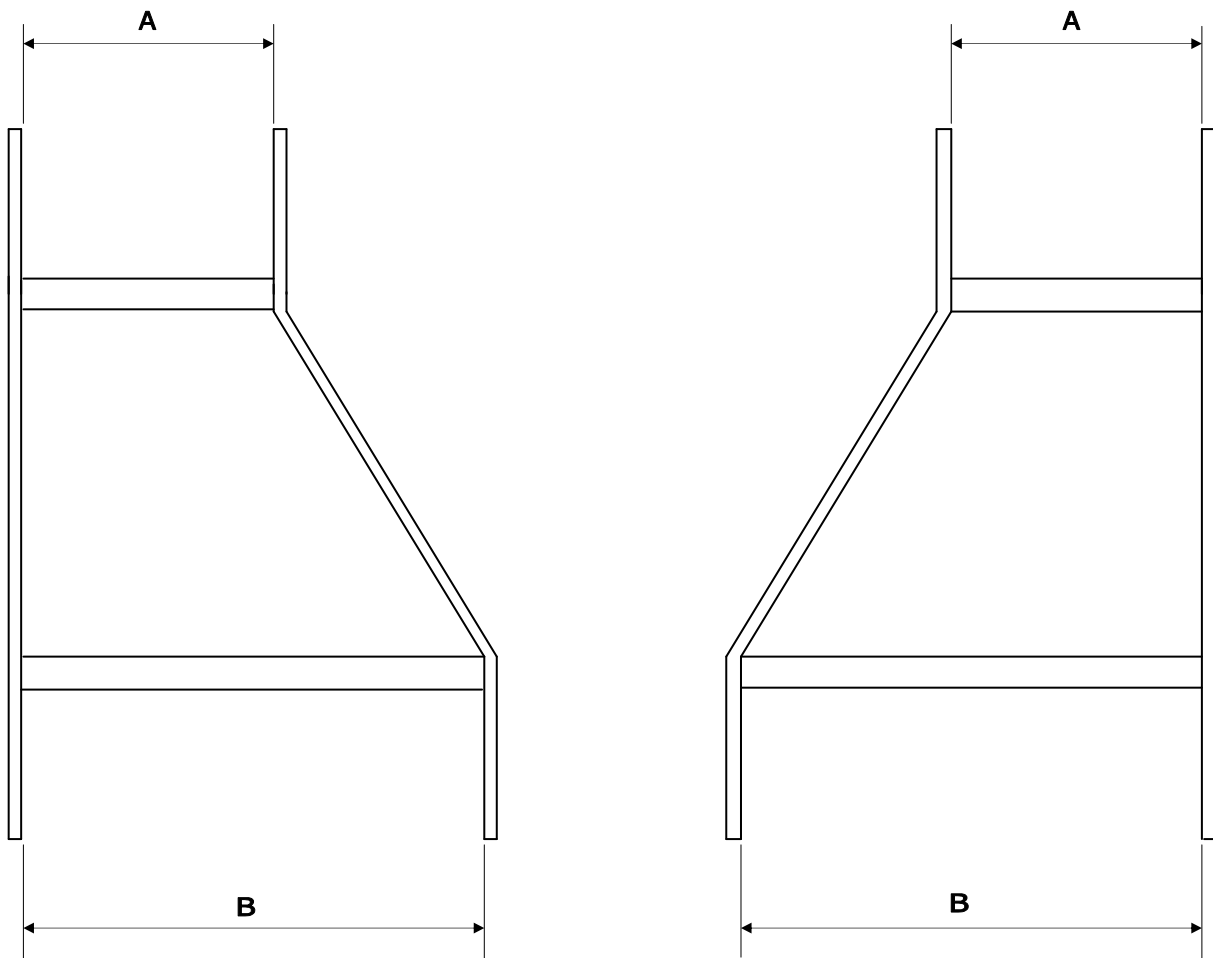

### **REDUCCION A DERECHAS / *RIGHT REDUCING***

REF.	BE-RD 0	BE-RD 1	BE-RD 2
A	230	400	600
B	400	600	910

### **REDUCCION A IZQUIERDAS / *LEFT REDUCING***

REF.	BE-RI 0	BE-RI 1	BE-RI 2
A	230	400	600
B	400	600	910

### **REDUCCION CENTRADA / *CENTER REDUCING***

REF.	BE-RC 0	BE-RC 1	BE-RC 2
A	230	400	600
B	400	600	910

NOTA: Indicar acabado de la pieza.

*NOTE: Indicate this finish of the piece.*

**TAPA PARA BANDEJA Serie BE / COVER TRAY BE Series**

TAPA SENCILLA (TP)  
SIMPLE COVER (TP)

TAPA TEJADILLO (TJ)  
COVER TOP (TJ)

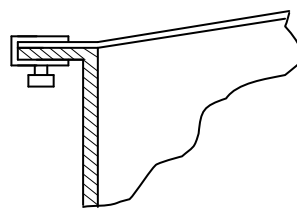
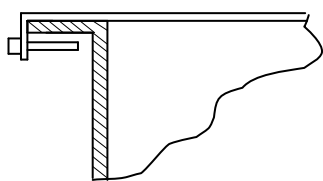
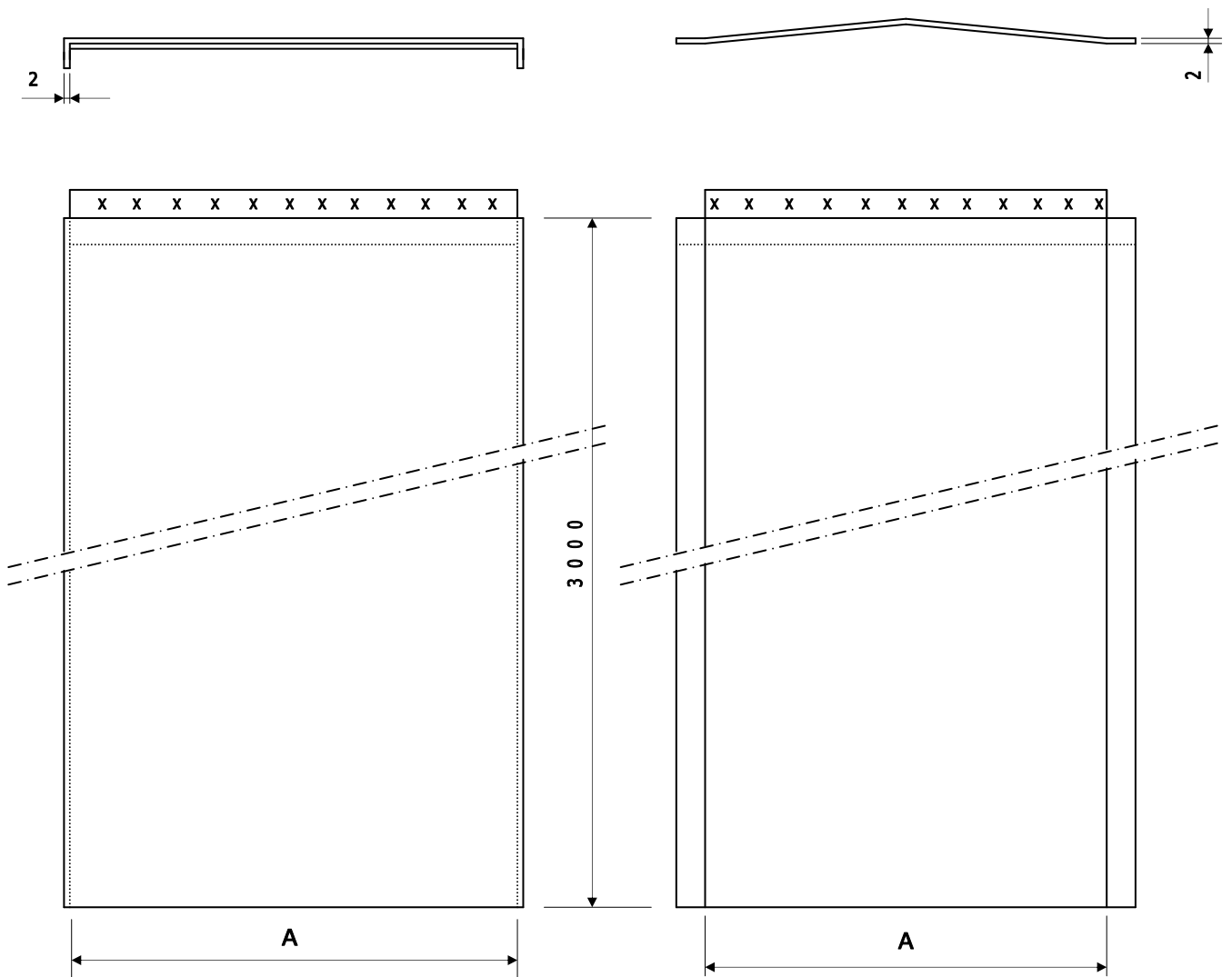

<b>REF.</b>	<b>BE-TP 0</b>	<b>BE-TP 1</b>	<b>BE-TP 2</b>	<b>BE-TP 3</b>
<b>A</b>	230	400	600	910
<b>REF.</b>	<b>BE-TJ 0</b>	<b>BE-TJ 1</b>	<b>BE-TJ 2</b>	<b>BE-TJ 3</b>
<b>A</b>	230	400	600	910

NOTA: Indicar acabado de la pieza.

*NOTE: Indicate this finish of the piece.*

## **SEPARADOR PARA BANDEJA Serie BE / SEPARATOR FOR TRAY BE Series**

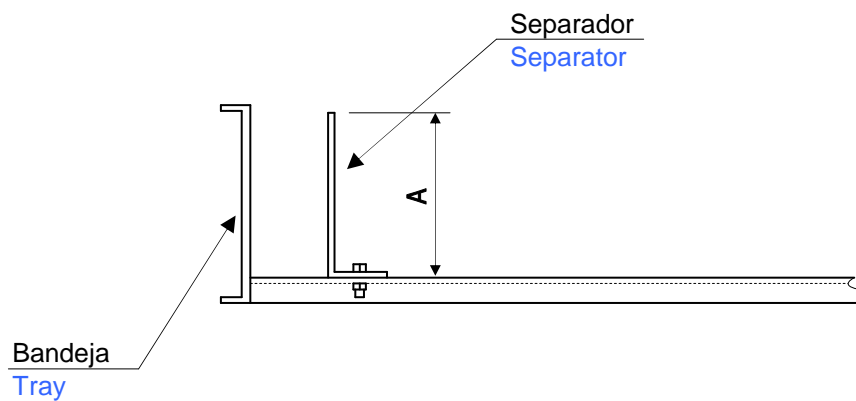

Es importante definir la distancia entre travesaños de la bandeja sobre la que va montado el separador.  
El tornillo de fijación es de M-6x15, con tuercas y arandelas.

*IT is important to define the distance between transoms of the tray on which the separator will be set.  
The screw of fixation is of M-6x15, with nuts and washers.*

REF.	BE-S 0	BE-S 1
A	80	130

## **GRAPA PARA BANDEJA Serie BE / CLAMP FOR TRAY BE Series**

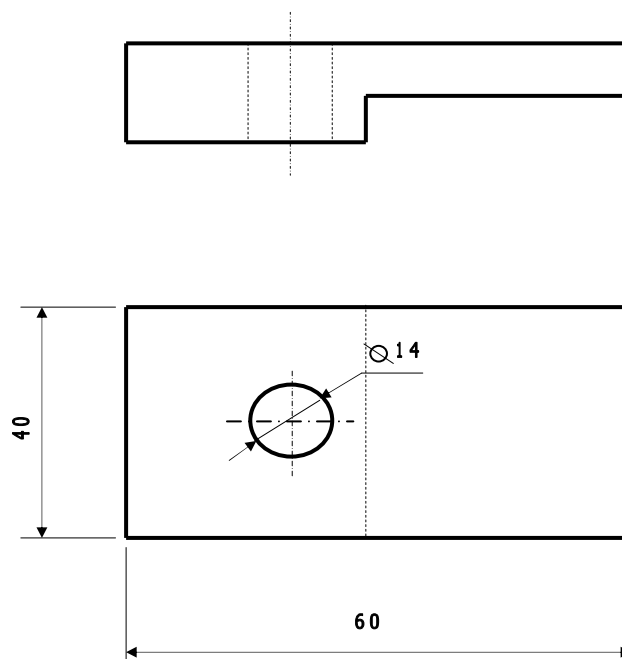

Se suministra sin tornillo.

*Supply without screw.*

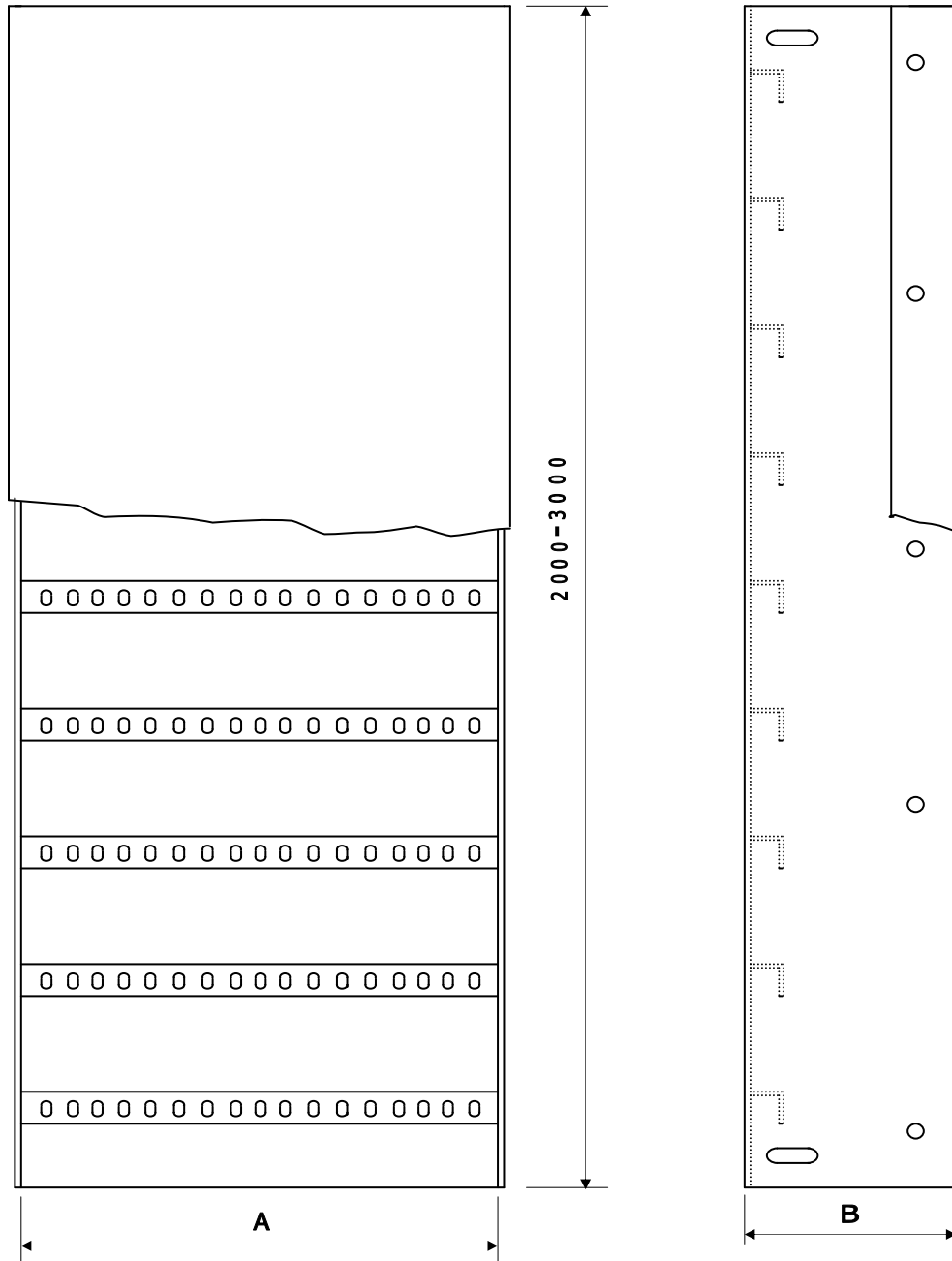

REF.	CT 0	CT 1	CT 2	CT 3	CT 4	CT 5
<b>A</b>	100	200	300	400	500	600
<b>B</b>	100	100	100	100	100	100

También se fabrican codos horizontales (90°, 60°, 45°), codos verticales (90°, 60°, 45°), Tes y Cruces.  
 NOTA: Indicar espesor y acabado de la pieza.

*Also horizontal elbows (90°, 60°, 45°), vertical elbows (90°, 60°, 45°), Tes and Crosses can be manufactured.*

*NOTE: Indicate thickness and the finish of the piece.*

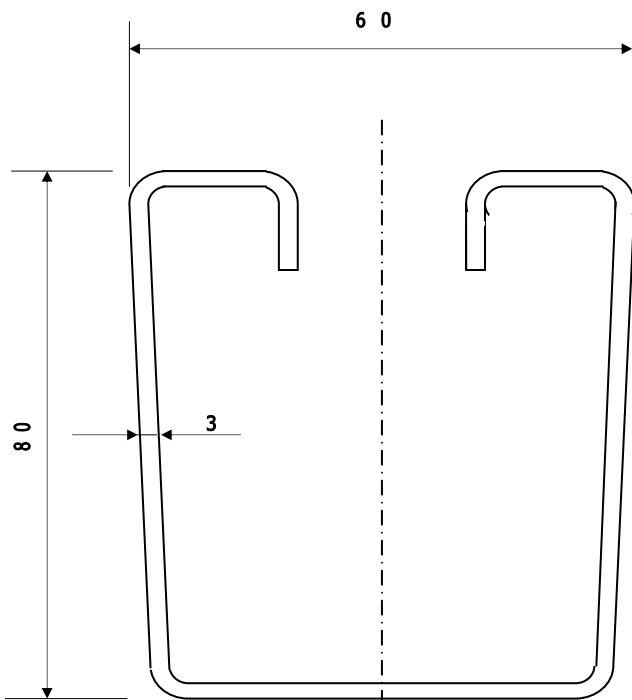

**Fig. (1)**

El soporte estructural de IESA se basa en un concepto de diseño que auna tres funciones determinantes en todo montaje mecánico: facilidad de montaje, robustez y versatilidad.

El sistema consiste básicamente en un perfil de chapa (Fig. 1) plegado de tal forma que permite deslizarse por su interior una grapa de acero estampada que se coloca en la placa de la ménsula o travesaño y que al ser puesta en posición de trabajo y apretada, nos asegura una unión firme y segura del elemento sobre el tramo descendente del soporte (Fig. 2).

El material es de acero de primera calidad y el acabado galvanizado por inmersión en caliente con una deposición de zinc de 70 micras. Las grapas y tornillería, electrocincada con 20 micras de espesor.

*The structural support is based in one design composed of 3 determinant functions during the mechanical assembly: simplicity, robustness and versatility.*

*Basically, the system consists of one profile of plate (Fig. 1) folded in such a way that it allows one stamped steel clamp to glide internally that is placed in the plate of bracket or tansom. It ensures us a firm and safe union of the element to the downward flight of the bear, when it is placed and tightened in its position.(Fig. 2).*

*They are made in first quality steel with hot dip galvanized finish and 70 microns of thickness. The clamp and screws, 20 microns of thickness.*

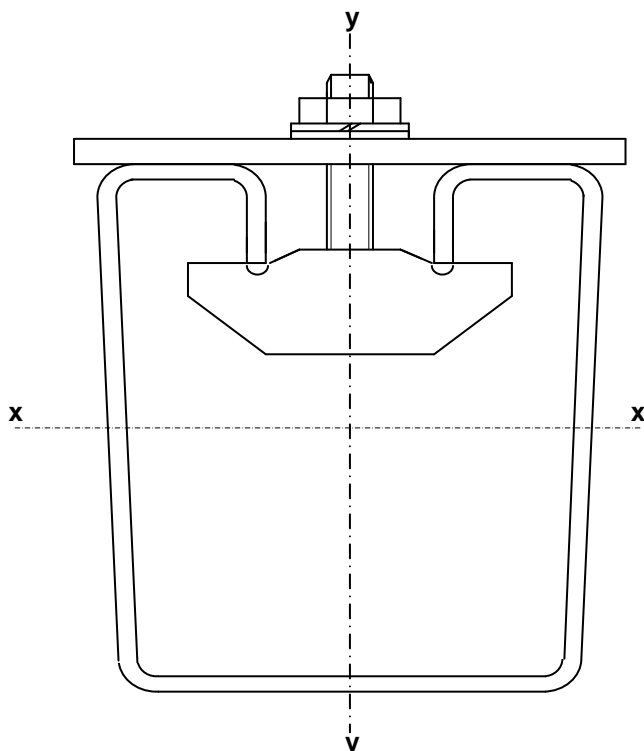

**Fig. (2)**

**DATOS PARA EL CALCULO**

**DATA FOR CALCULATION**

**EJE xx / AXLE xx**

Momento de Inercia  $I_{xx} = 30,445 \text{ cm}^4$   
*Moment of inertia*  $I_{xx} = 30,445 \text{ cm}^4$

Módulo resistente  $W_{xx} = 7,574 \text{ cm}^3$   
*Resistant turning*  $W_{xx} = 7,574 \text{ cm}^3$

Radio de giro  $i_{xx} = 2,021 \text{ cm}$   
*Radius of twist*  $i_{xx} = 2,021 \text{ cm}$

**EJE yy / AXILE yy**

Momento de Inercia  $I_{yy} = 39,338 \text{ cm}^4$   
*Moment of inertia*  $I_{yy} = 39,338 \text{ cm}^4$

Módulo resistente  $W_{yy} = 13,113 \text{ cm}^3$   
*Resistant turning*  $W_{yy} = 13,113 \text{ cm}^3$

Radio de giro  $i_{yy} = 2,297 \text{ cm}$   
*Radius of twist*  $i_{yy} = 2,297 \text{ cm}$

## SOPORTES ESPECIALES Serie SE / SPECIALS SUPPORTS SE Series

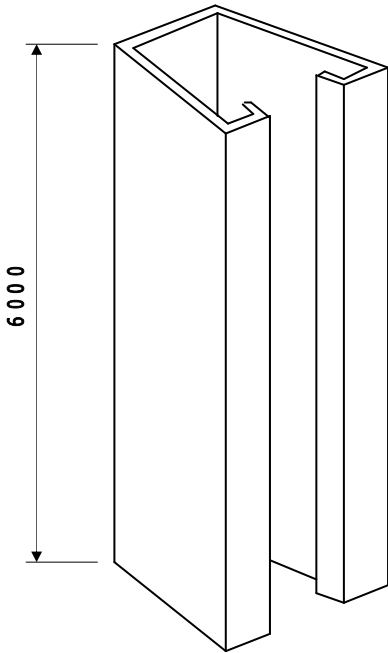

El tramo recto sin taladros ni patillas tiene REF. SE  
*The straight section without holes or whiskers has SE reference.*

Con patillas para empotrar tiene REF. SEP  
*With whiskers has SEP reference.*

Con taladros para taco de expansión tiene REF. SEA  
*With holes for stopper of expansion has REF. SEA*

La referencia se compondrá poniendo las letras de la serie y a continuación la longitud deseada.  
*The reference will compose putting the letters of the series and to continuation the length wished.*

Se puede suministrar hasta en longitud de 6.000 mm.  
*It can be supply up to 6.000 mm length.*

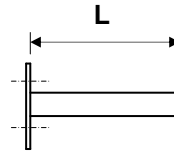
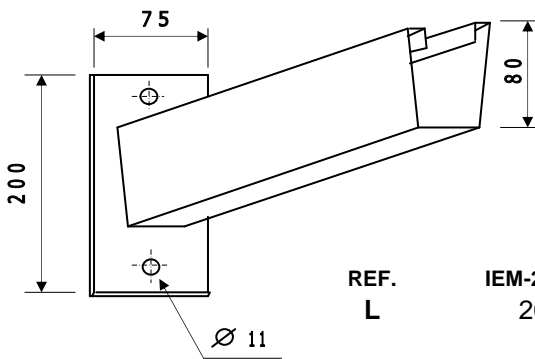

### MENSULA TIPO IEM / BRACKET IEM TYPE

REF.	IEM-200/80	IEM-250/80	IEM-350/80	IEM-500/80	IEM-650/80	IEM-850/80
L	200	250	350	500	650	850

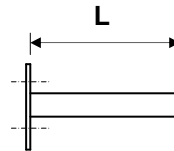
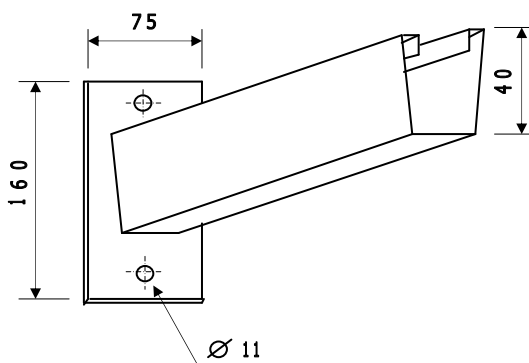

### MENSULA TIPO IEM / BRACKET IEM TYPE

REF.	IEM-200/35	IEM-250/35	IEM-350/35
L	200	250	350

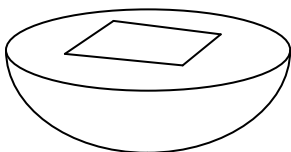

### PROTECTOR SEPA / PROTECTOR SEPA

Se aconseja el montaje del protector de caucho SEPA en tramos, tanto horizontales como verticales, que estén en zonas de paso, para evitar accidentes.

*It is recommended to assemble of the protector of rubber SEPA in flights, both horizontals and verticals, which are in transit zones..*



**SOPORTES ESPECIALES Serie SE / *SPECIALS SUPPORTS SE Series***

**TIPO IED / *IED TYPE***

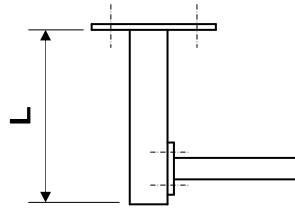
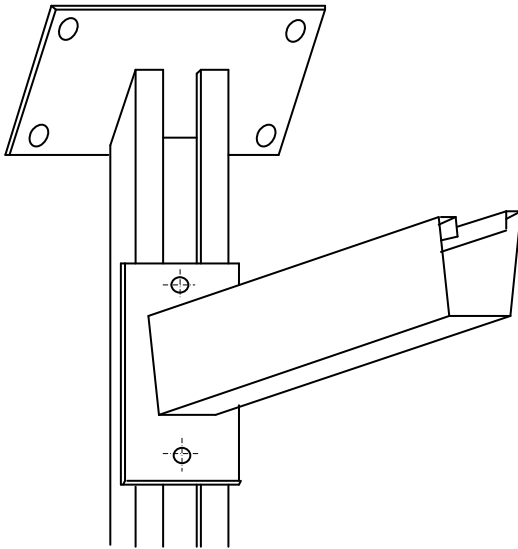

REF.	IED 10	IED 15	IED 20	IED 25	IED 30
L	1000	1500	2000	2500	3000

**TIPO IES / *IES TYPE***

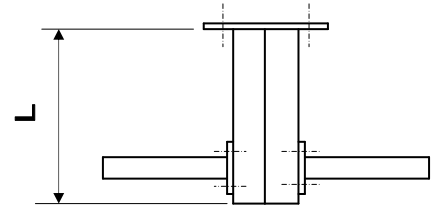
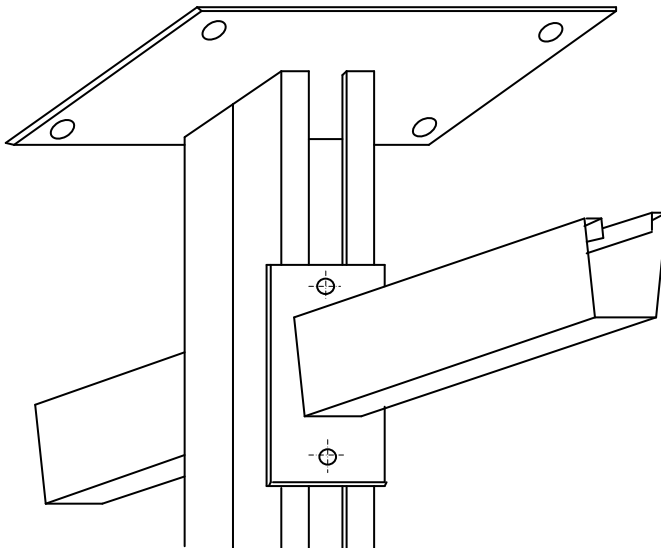

REF.	IES 10	IES 15	IES 20	IES 25	IES 30
L	1000	1500	2000	2500	3000

**TIPO SET / *SET TYPE***

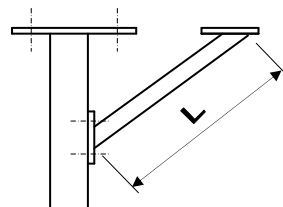
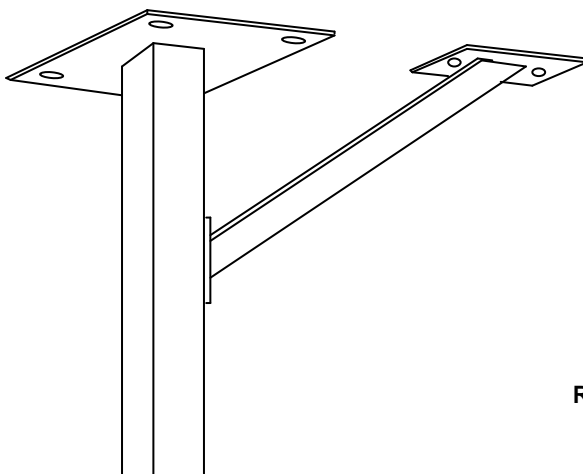

REF.	SET 75	SET 10	SET 12
L	750	1000	1200

**SOPORTES ESPECIALES Serie SE / *SPECIALS SUPPORTS SE Series***

**TIPO IET / *IET TYPE***

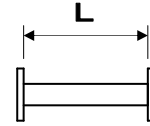
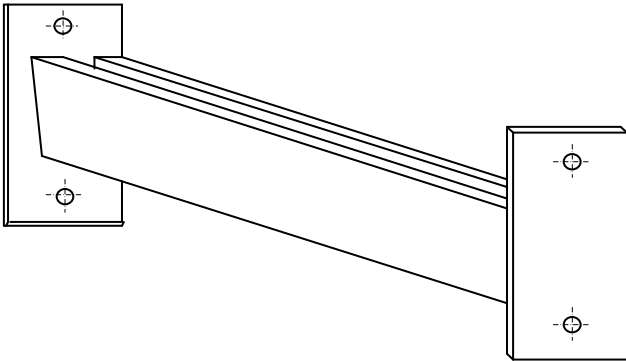

REF.	IET 25	IET 35	IET 50	IET 65	IET 85	IET 100
L	250	350	500	650	850	1000

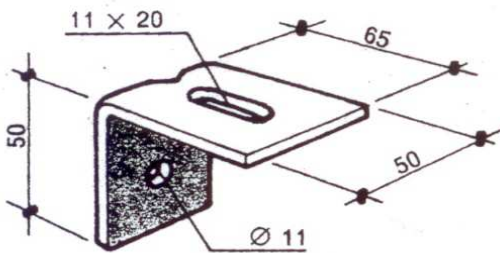

**REFERENCIA SEE** *REFERENCE SEE*



**GRAPA REFERENCIA SEB**

*CLAMP REFERENCE SEB*

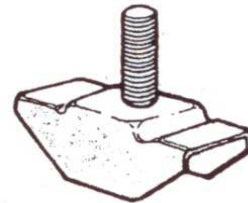

**GRAPA REFERENCIA SEG**

*CLAMP REFERENCE SEG*

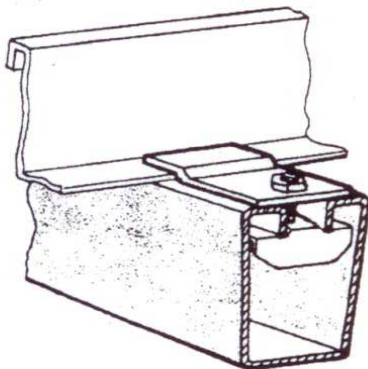

**Detalle fijación bandeja**

**GRAPA SEG**

**GRAPA SE**

*Retail of tray fixation*

*CLAMP SEG*

*CLAMP SE*

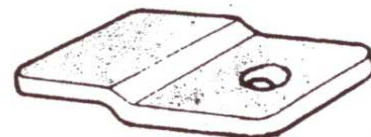

**GRAPA REFERENCIA SEX**

*CLAMP REFERENCE SEX*

**MONTAJE SOBRE SUELO**  
*FLOOR ASSEMBLY*

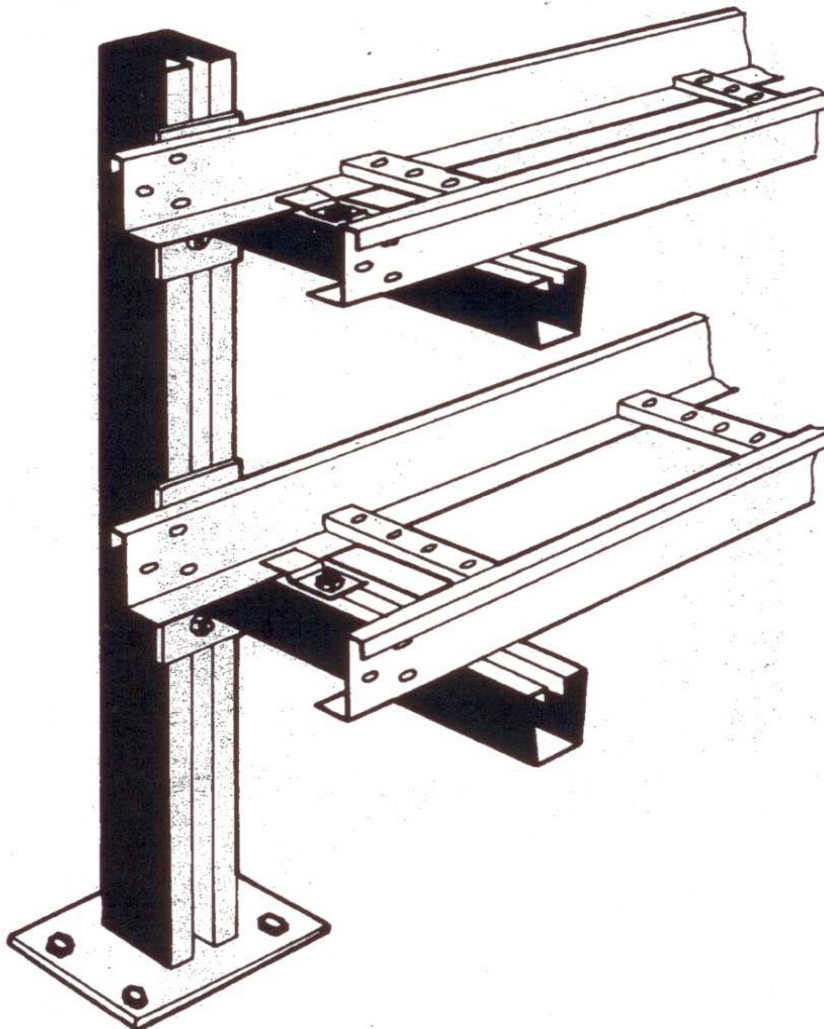

Esta solución está especialmente indicada para tendidos con poca carga de cables. Se recomienda que la altura del tramo vertical IED no sea superior a 1.500 mm. El anclaje al suelo se consigue con 4 tornillos de M-14.

Los apoyos tienen la referencia IEM.

*This solution is specially indicated for electrical installations with low load of cables. It is recommended that the height of the length vertical IED not exceed 1.500 mm. The anchorage to the floor is obtained with four M-14 screws.*

*The supports have the reference IEM.*

**MONTAJE SOBRE SUELO**  
*FLOOR ASSEMBLY*

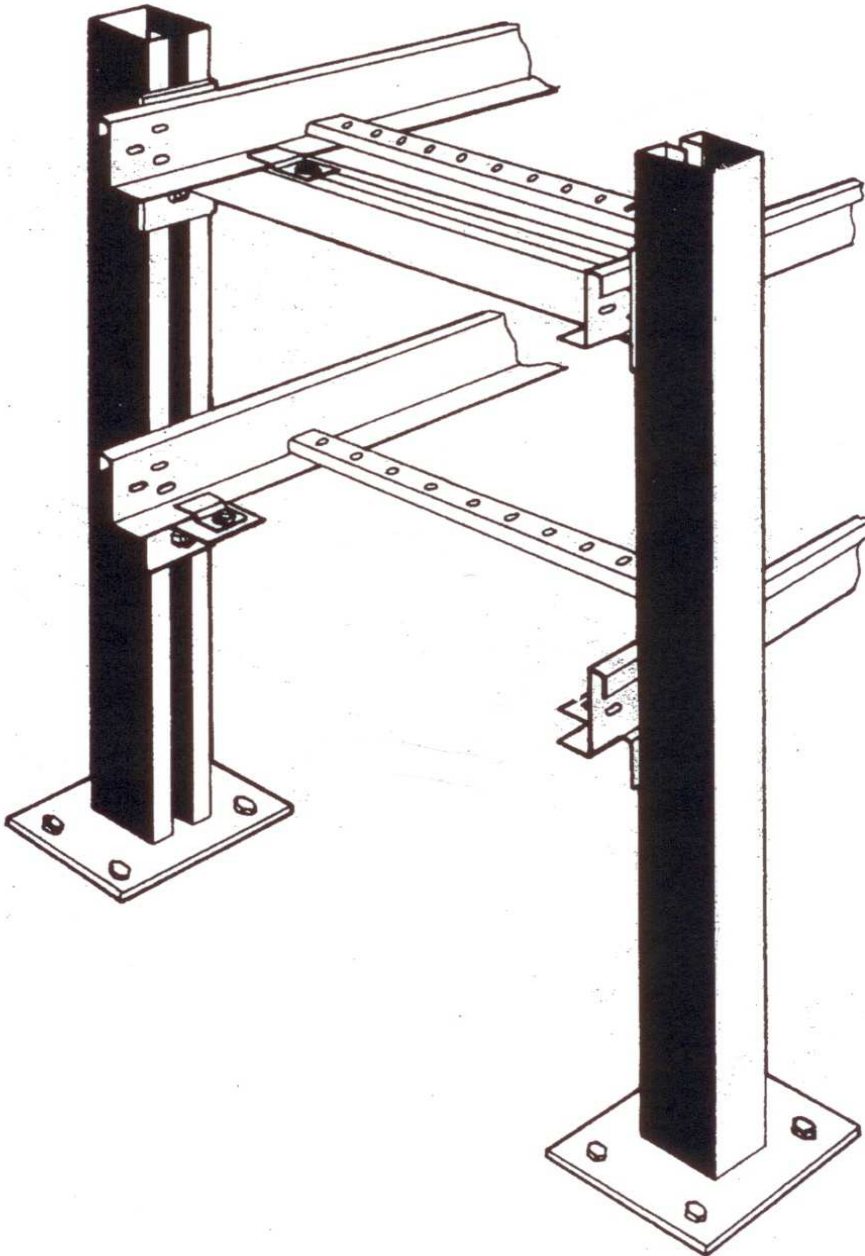

Este tipo de montaje permite el tendido de cables con mucha carga, hasta alturas de 3.000 mm. El tramo vertical tiene la referencia IED y el travesaño se denomina IET. También se pueden montar las bandejas sobre escuadras SEE.

*This type of assembly allows heavy load electrical installation up to 3.000 mm heights. The length vertical has the reference IED and the transoms is named. The trays also can be assembled on SEE squares.*

**MONTAJE SOBRE TECHO**  
*ROOF ASSEMBLY*

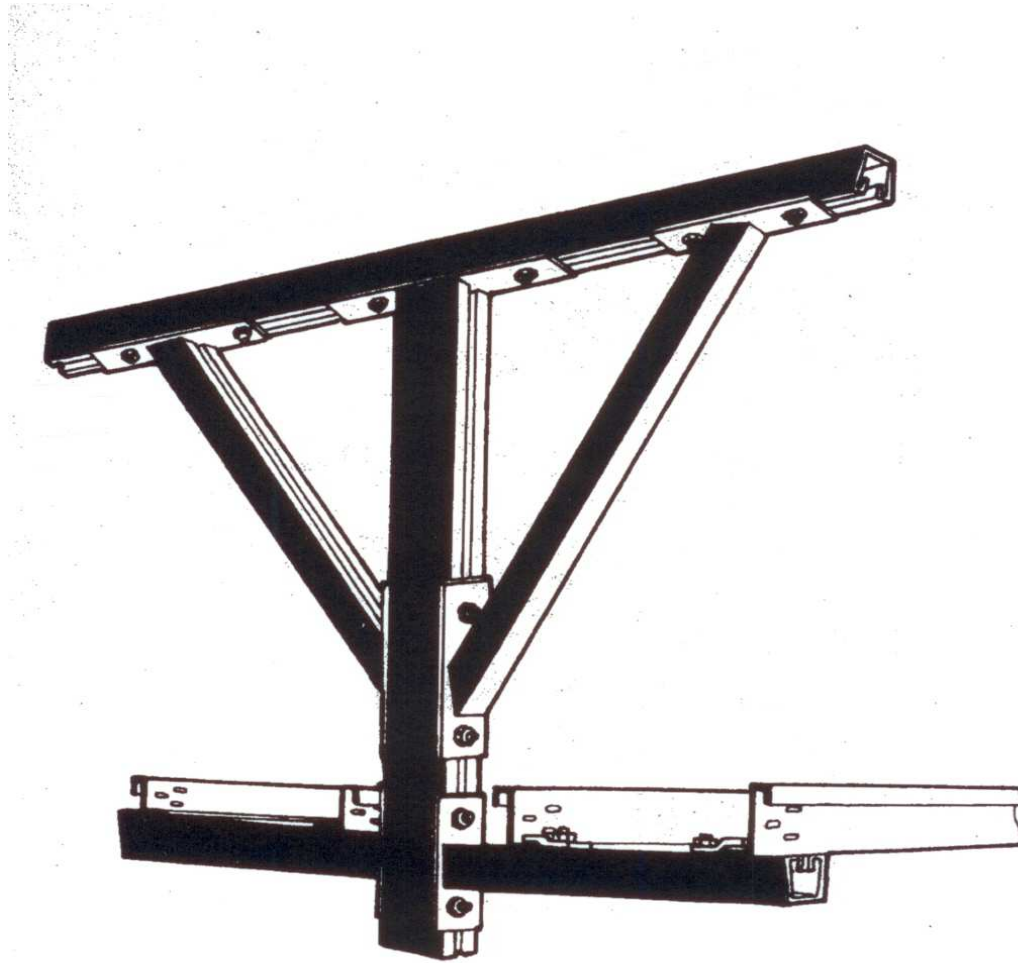

Este sistema de montaje posibilita el montaje de bandejas en instalaciones en las cuales el techo sea de hormigón.

Puede hacerse según se indica en el dibujo, o bien anclando los tramos descendentes tipo IED (sencillo) ó IES (doble) directamente al techo.

Cuando se trate de cargas descentradas se recomienda usar los tirantes a ambos lados SET, así como en el caso de que el tramo descendente sea superior a 3.000 mm. y la bandeja superior a 300 mm. de ancho.

Para una perfecta alineación se recomienda el montaje tal como aparece en le dibujo.

*This system facilitates the assembly of trays in installations with concrete roof. It can do it as in draw above, or anchoring the downward lengths IED type (simple) or IES (double), directly to the roof.*

*When it should refer to off-centre loads, it is recommended to use the braces on both SET sides, also if the downward length is bigger than 3.000 mm and the tray exceeds 300 mm of wide.*

*It is recommended to do the assembly as draw above for a perfect alignment.*

**SOPORTES ANCLADOS A MURO**  
*SUPPORTS ANCHORED TO WALL*

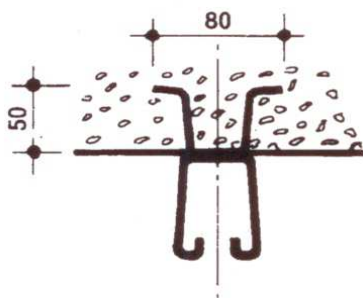
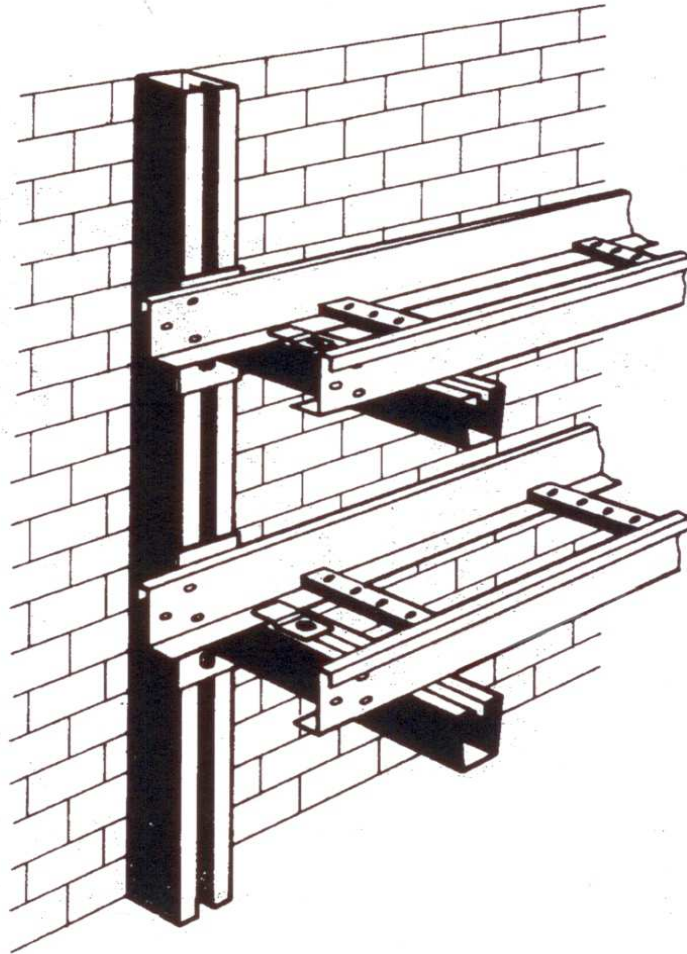

CON PATILLAS PARA EMPOTRAR  
*WITH SUBJECTIONS BUILT IN*



CON TACOS PARA FIJAR  
A TACO DE EXPANSION

*WITH PLUGS TO FIX  
TO PLUG OF EXPANSION*

Las patillas para empotrar, así como las perforaciones para tacos de expansión, van emplazadas cada 500 mm.

El perfil en ambos casos soporta cargas hasta 1.400 Kg/m.

*These products as well as the boxes of expansion plugs are located each 500 mm.  
The profile, in both cases, bears up to 1.400 Kg/m.*

**SOPORTES Serie S / *SUPPORTS S Series***

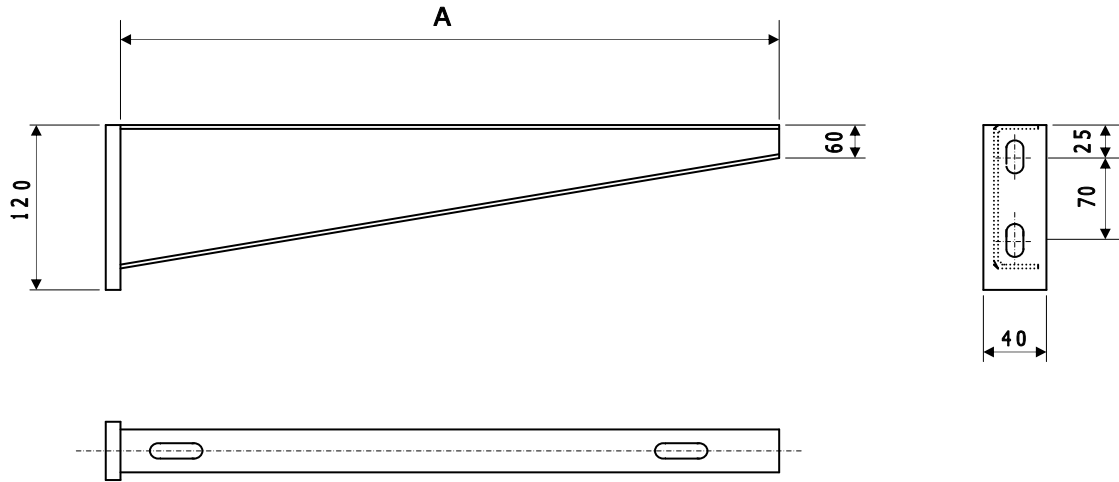

Ref.	S 0	S 1	S 2	S 3	S 4	S 5	S 6
A	150	250	350	450	550	650	750

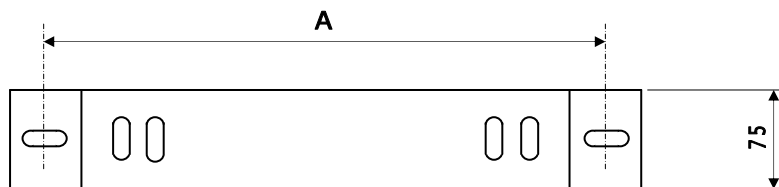
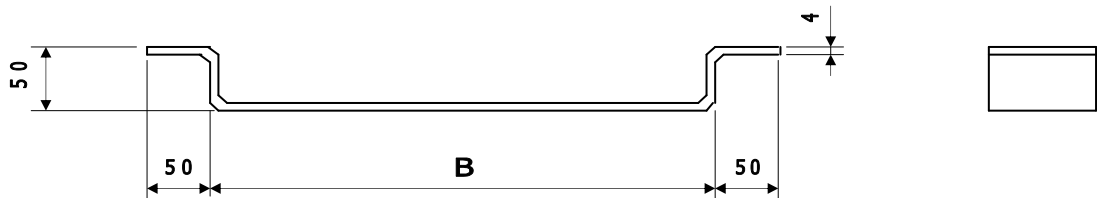

Ref.	S 60	S 61	S 62	S 63	S 64
A	140	200	325	525	725
B	90	150	275	475	675

**RAILES Serie RL-RP / *RAILS RL-RP Series***

**RAIL LISO / *SMOOTH RAIL***

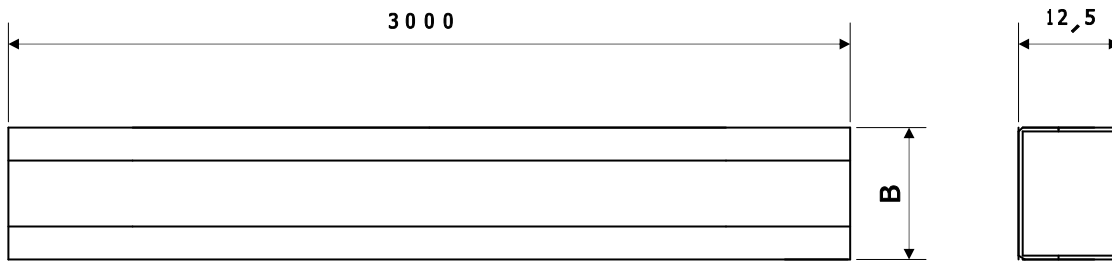
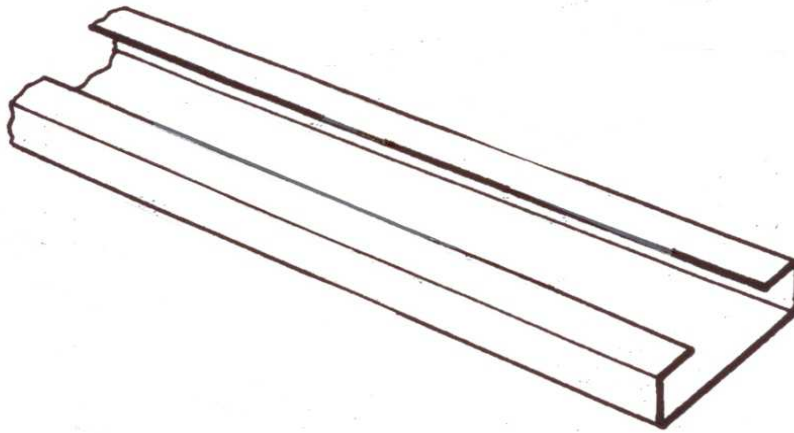

**RAIL PERFORADO / *PERFORATED RAIL***

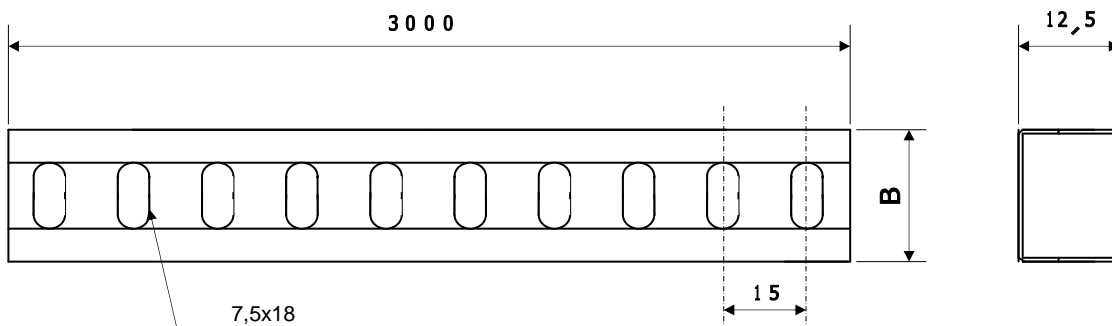
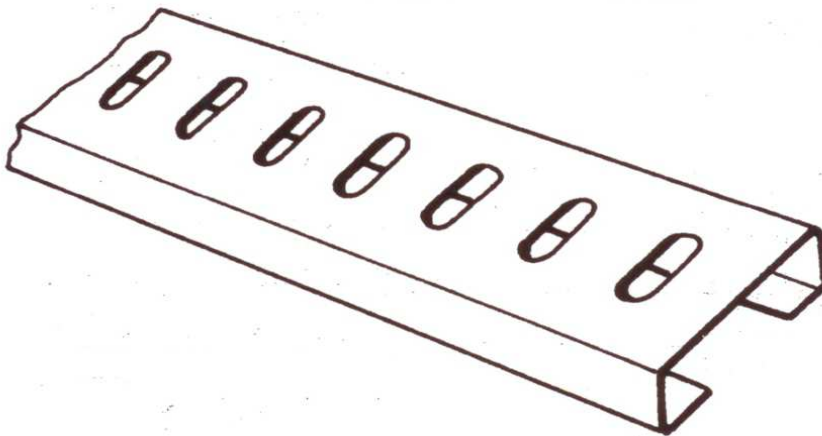



## GRAPAS PORTACABLES SOBRE RAIL Serie GP / *CLAMPS GP Series*

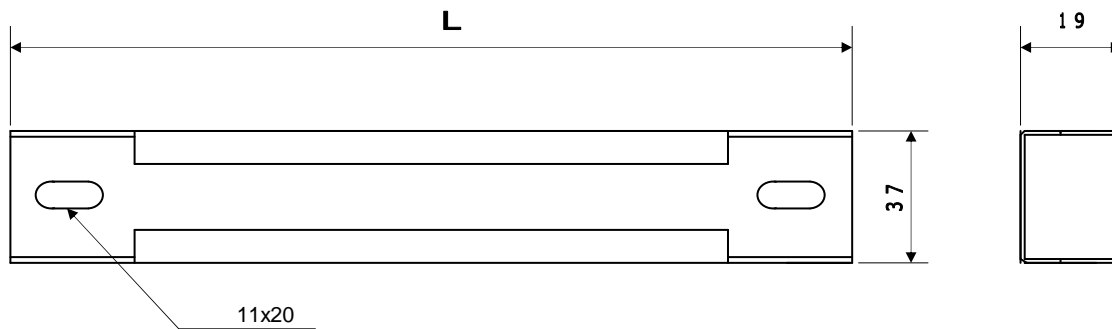

**MATERIAL : CHAPA DE ACERO DE 2 mm DE ESPESOR GALVANIZADA**

***MATERIAL : STEEL PLATE OF 2 mm OF THICKNESS GALVANIZED***

**L = 500 - 800**

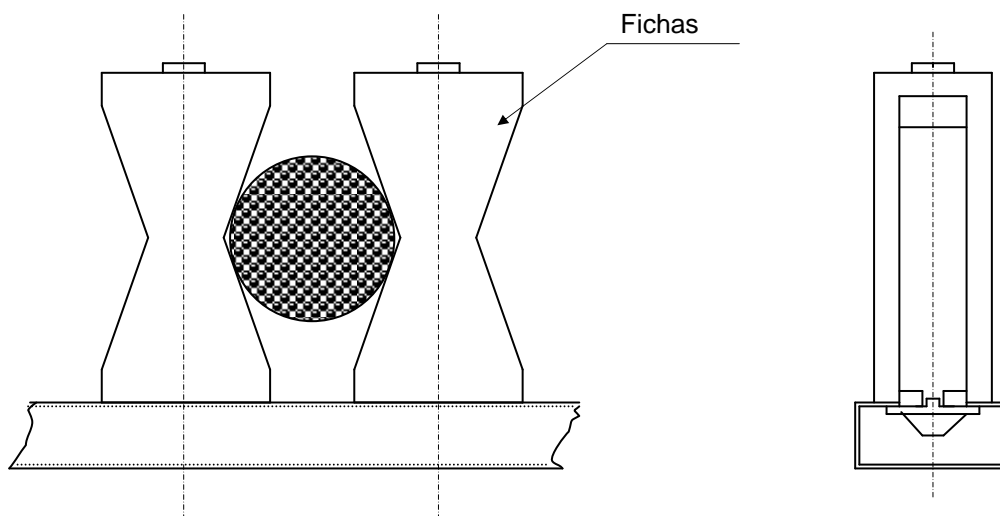

**MATERIAL NYLON (Color Negro)**

***MATERIAL NYLON (Black)***

REF.	Cable $\varnothing$ mm
GP02	14-48
GP03	24-72